

MADDY BOSTRIDGE

CRAFT REFUGE



CONTENTS

CHAPTER 1

WHAT IS A TENT
TENT WASTE

CHAPTER 2

REFUGEES
ART WITH REFUGEES

CHAPTER 3

TRIP TO THE MIDDLE EAST

CHAPTER 4

TENT EXPERIMENTS

CHAPTER 5

WEAVING WORKSHOP

CHAPTER 6

POTTERY WORKSHOP

CHAPTER 7

WOOD WORKSHOP

STATEMENT

I started this project with the observation of tents. I watched as thousands of festival goers discard perfectly good tents at the end of weekends. Simultaneously, these identical layers of nylon could mean the difference between life and death, for refugees living in unfathomable conditions globally. Once a tent is broken its now unfit as a shelter it becomes a waste of space, but the materials stay the same. I want to change people's perspective on the potential of what it is they are really throwing away and what good can be made of what is essentially a rolled-up bag of usable matter. Shelter is one of the essentials a person needs to survive, however I'd like the bridge the gap between survival and living an enriched life. I proceeded to collect these materials and repurpose them to create tools for refugees to use in a workshop that travels to them. Tools that can be used to celebrate the traditional craft originating in country's refugees have been forced to flee. Creating a space that gives them the chance to regain what they have left behind and ease the detachment from home.



Chapter 1

WHAT IS A TENT?

THE POLES are often fibre-glass with either galvanised steel connectors, with elastic throughout.

THE ZIPS are aluminium

THE GUY ROPES are polyester/ Polypropylene

THE BAGS AND GROUND SHEET is usually Polyethylene Tarpaulin, which will melt!

THE FLYOVER Can Often be polyester or nylon.

THE PEGS are eith galvanised steel, plastic or aluminium



TENT WASTE

The manufacture of typical 3.5kg tent emits the equivalent of as much as 25kg of carbon dioxide, and contains the equivalent of around 8,750 straws or 250 pint cups of plastic.

Why don't people care about their tents?



1 IN 5 Festival goers have left camping equipment

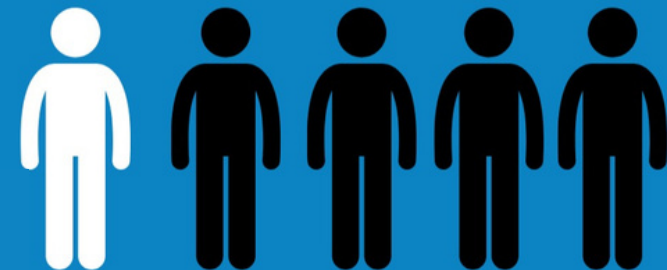

Chapter 2 REFUGEES



ART AND REFUGEES



UNHCR World Refugee Day Art exhibition, Amman, Jordan, 2014



Amal, The travelling refugee puppet, Venice, Italy



Issam Kourbaj, Dark water, burning world. Hastings museum Nov 2021. Kourbaj made 1000 boats packed with burnt matchboxes to resemble refugees crossing the channel.

MEETING AMAL



Amal is an example of using craft to teach so many people what a refugee might have gone through. She creates an atmosphere of unity, respect and empathy. I went to give her an umbrella i made to welcome her to the UK.

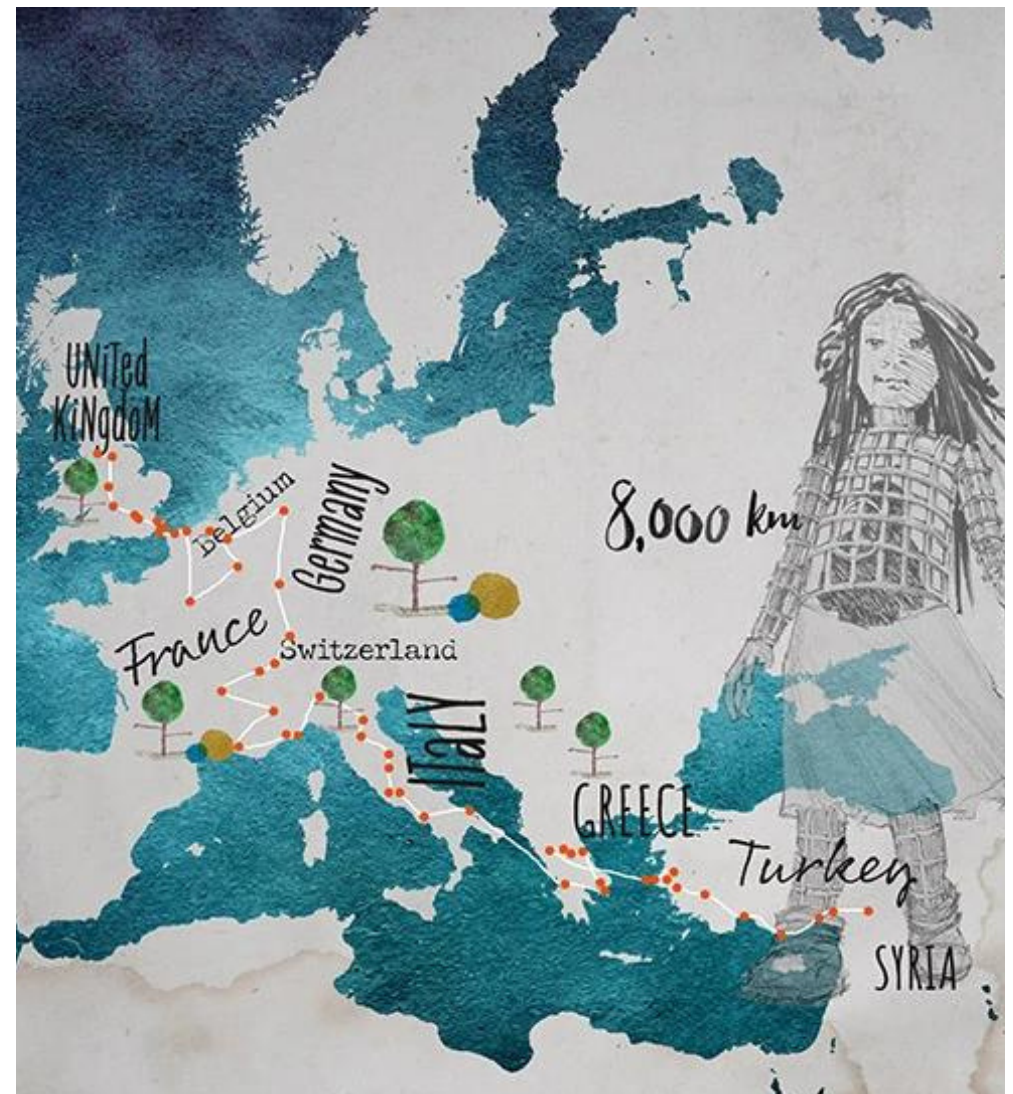

She has walked all the way from Syria.

Chapter 3

A TRIP TO THE MIDDLE EAST - JORDAN

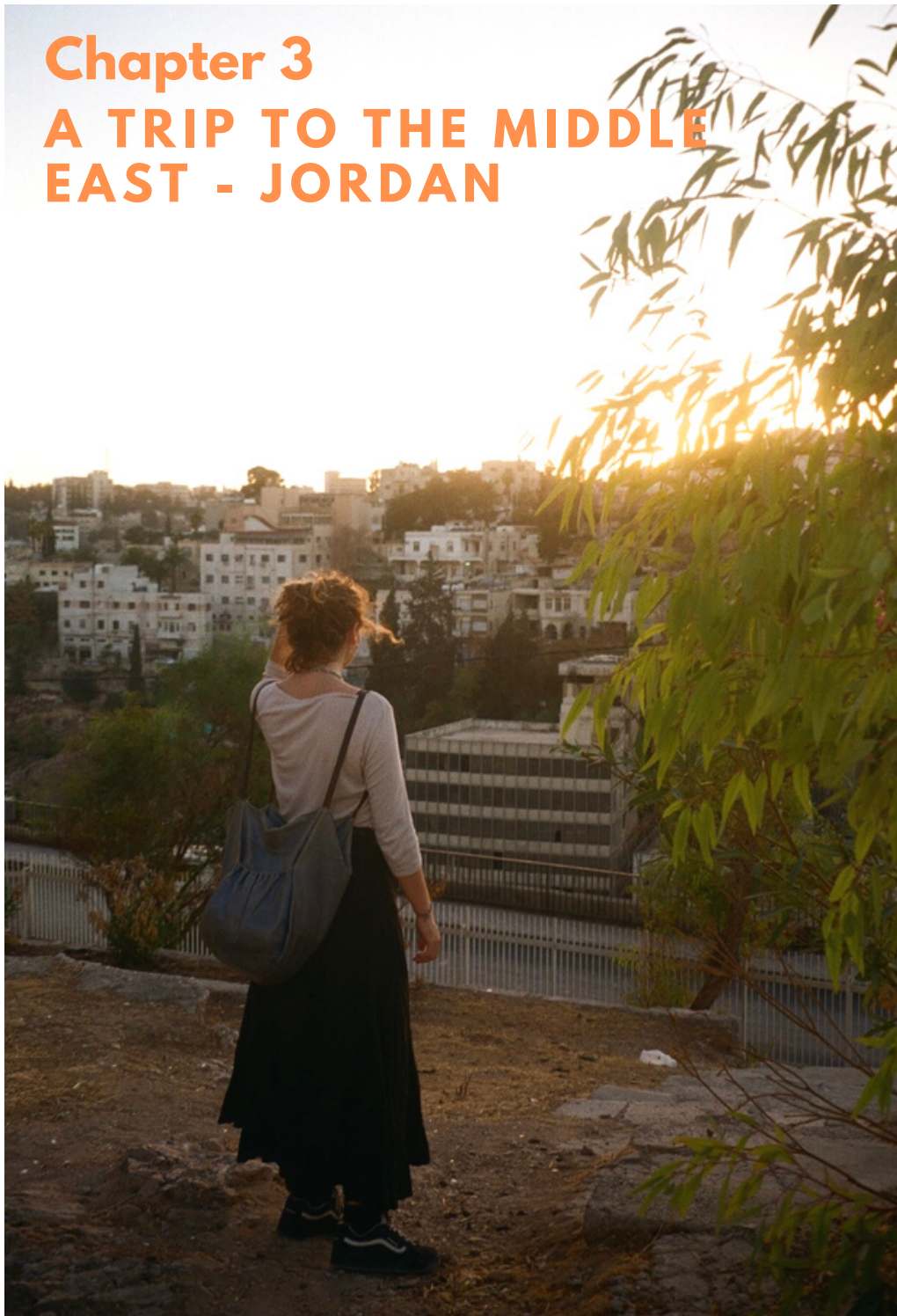

TO LEARN ABOUT THE CULTURE AND CRAFTS THAT MANY REFUGEES HAVE TO LEAVE BEHIND





I saw many people taking broken objects and creating new ones from parts. Very little is going to waste here.

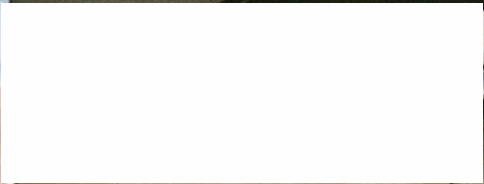



People have narrow workshops that pour out onto the streets where they often work on to trestles, doing wood work, welding, ceramics, textiles and more. This creates a load and lively atmosphere that trades at an honest face value. People are amazing at their craft having done it for so many years but are still so open to learn and are so humble about their skills.

THERE'S SO MUCH
CRAFT!



AND WORKSHOP
COMMUNITY.



There's districts in the city of Amman that are networks of makers. Built on generosity and trust. Everyone is a friend or family and are so willing to help each other.



In a small Ceremics workshop in the old quarters of Amman women throw pots, paint pottery and build mosiac's the space felt so welcoming and safe. A place where women share stories they are brought together by the craft.

Yarn is hand spun with the wool from sheep in Madaba and other rural villages. It is then hand dyed before being woven at home using a ground loom very old weaving technique.



So many Pomegranates! They grow here and are written in the history of almost all religions, they are believed to enhance health and fertility as well as signify life and death.



Keeping and training pigeons' is a tradition in Jordan. People feed them and have enclosures on their rooftops. The pigeons' know to come home everyday at sun set, they circle overhead on route home, dancing to the sound of the call to prayer.

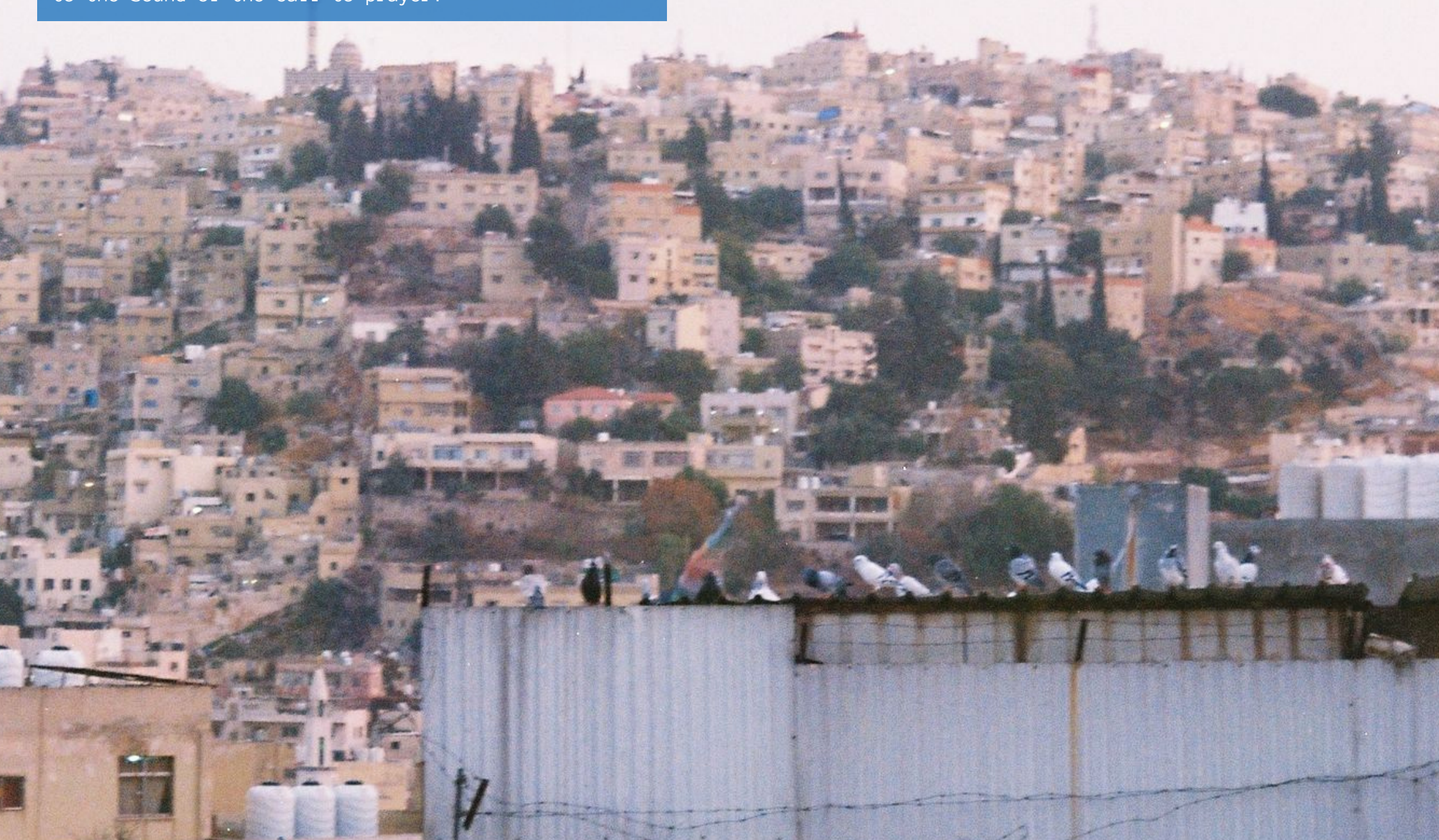

Chapter 4

TENT EXPERIMENTS

How can I use tents as a material to bring to life middle eastern culture?



Palestinians keep hold of the old keys of their homes, with the hopes to return one day.

I started thinking of any workshops, sentimental objects or activities that refugees from different places could be interested in.

Starting small by shaping the tent pegs into keys to create games for children to play.



CARDAMON COFFEE SHARING UTENSILS



POMEGRANATE OIL BURNERS



Bells are attached to the feet of pigeons' in Jordan so they rattle when they fly over head.



Bells made for a workshop proposal, making door bells for temporary living in refugee camps.

KITE FIGHTING

A tradition in many middle eastern countries, I could use tents to run workshops in making your own kite.



Collecting tent waste.



Running workshops for refugees using the tools.

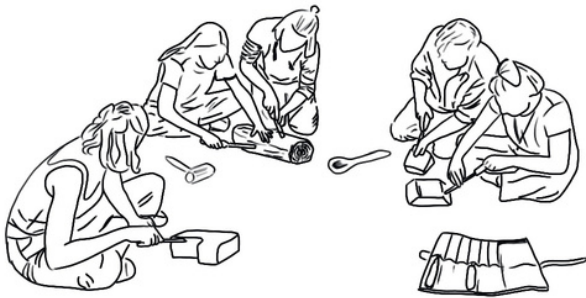

Separating the materials.

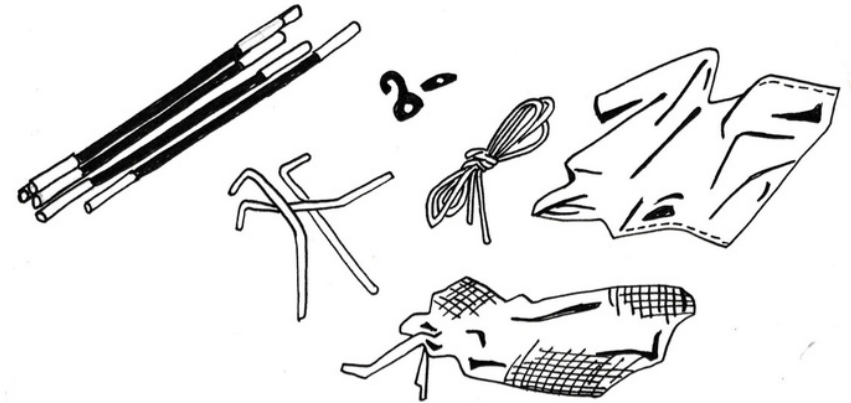

Designing tools.

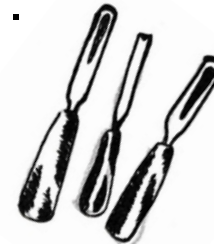

Chapter 5

WEAVING WORKSHOP





A PORTABLE LOOM USING TENT COUNTERPARTS

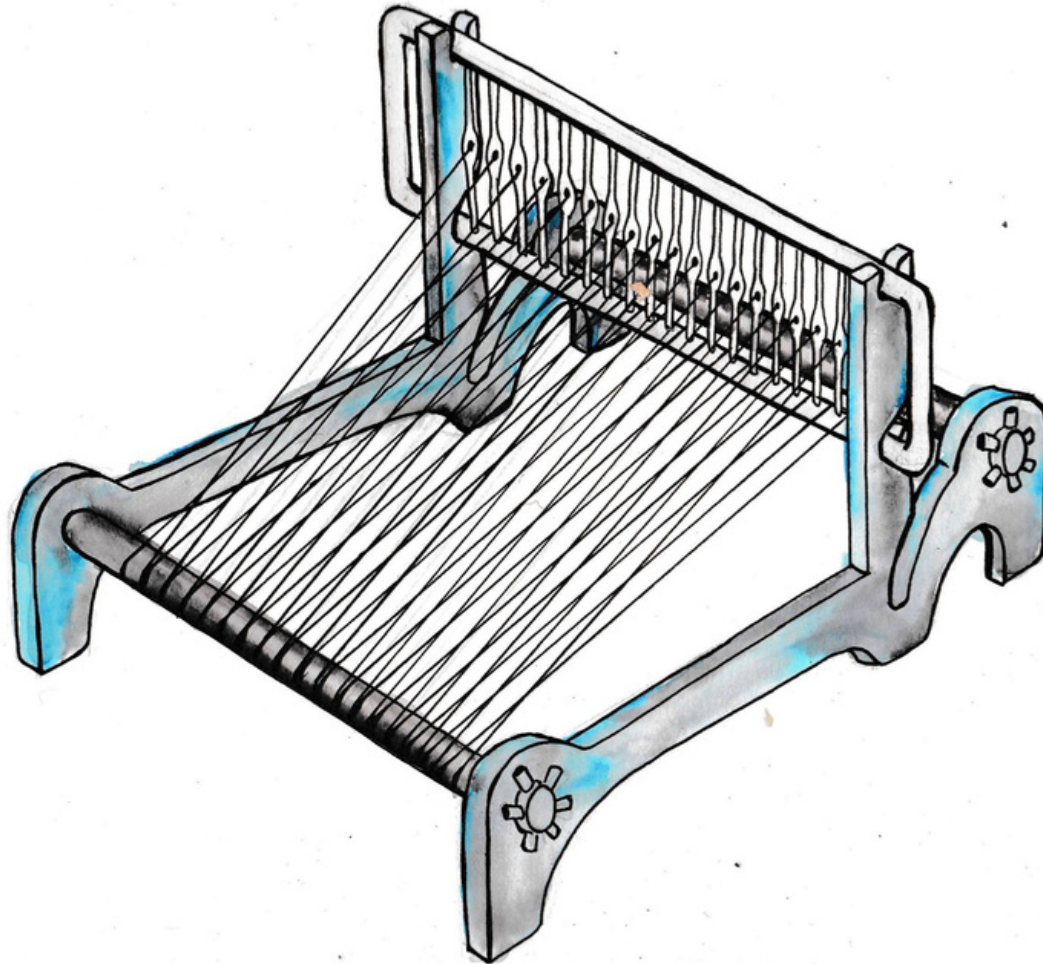

Welded tent pegs and
gazebo poles.

Melted ground sheet/
clips and fastenings.

Tent poles fixed together.

Yarn spun from the fly over material.



Chapter 6 POTTERY WORKSHOP



TENT COUNTERPARTS



Melted ground sheet, compressed into a throwing bat.

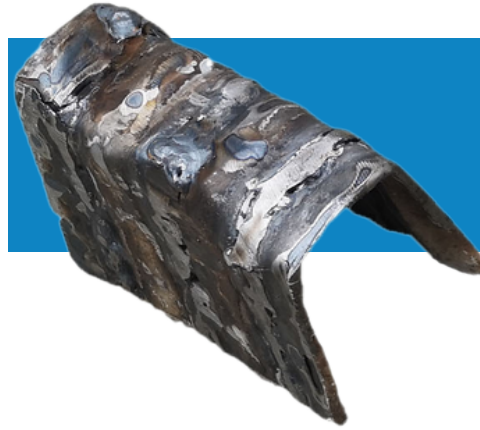

Flattened layered and welded, gazebo poles.



A pedal for a pottery wheel.



Can be used as fixing once bent and bolted.

A PORTABLE THROWING WHEEL

Melted ground sheet, pressed
and lathed to create the bat.

Recycled steel from local scrap yard.

Textiles taken from tent flyover.

Bicycle wheel packed with ground
sheet for the bottom disk.

Tent poles fixed together for a kick stick.

Guy ropes knotted and used to suspend the
kick stick.





Chapter 7
WOOD WORKSHOP

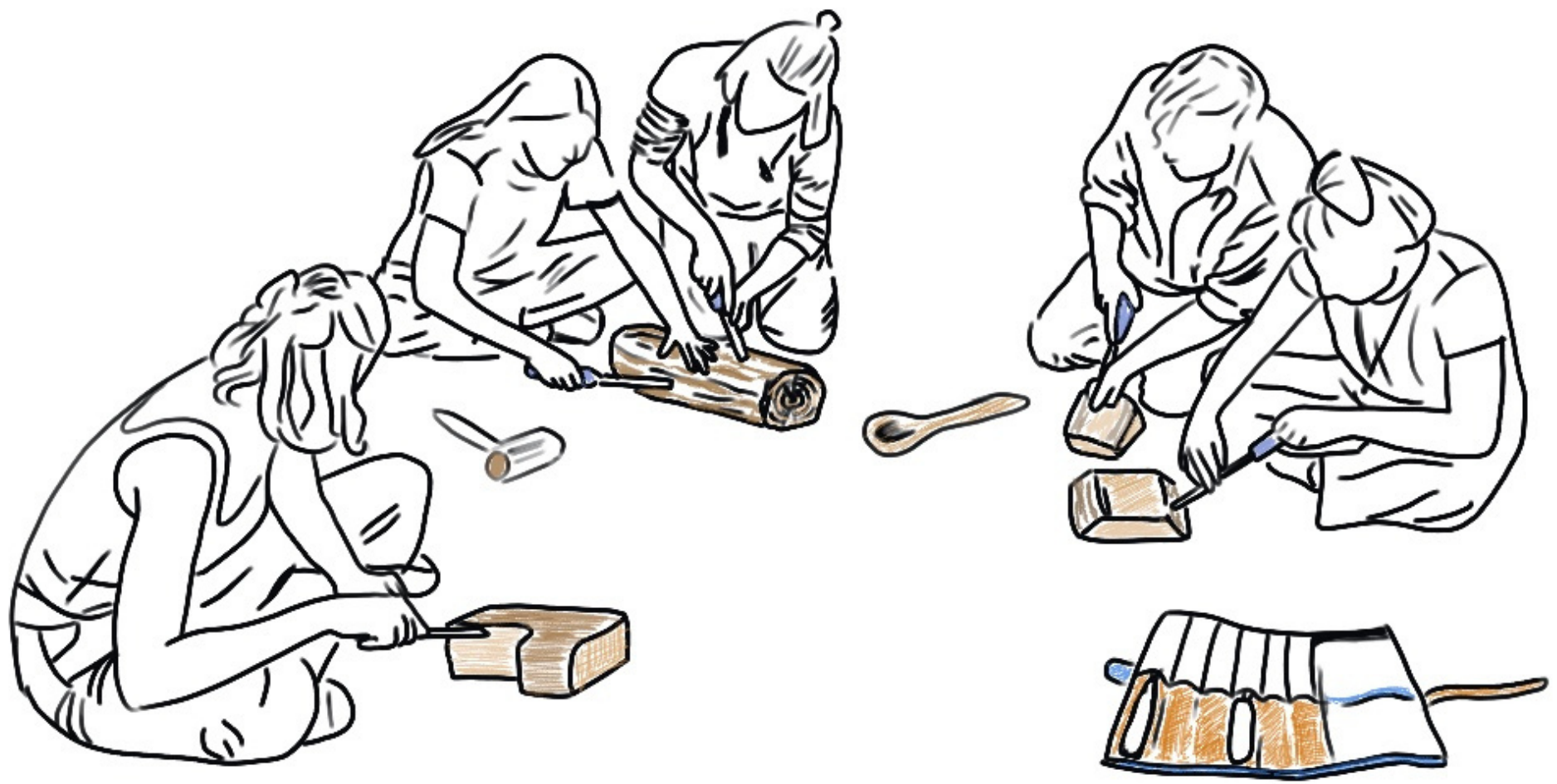

A WOOD CARVING SET

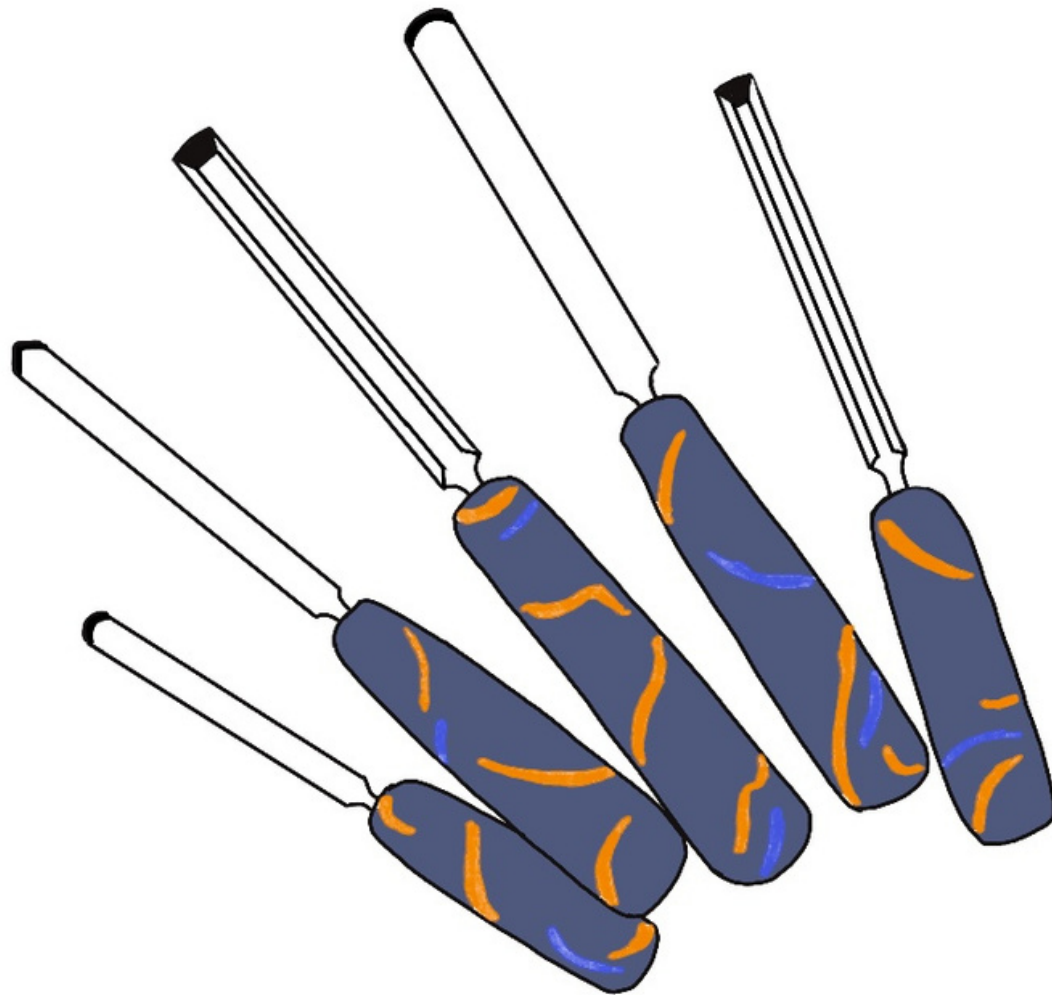

Welded finished and sharpened tent pegs.

Melted shaped and smoothed ground sheet mixed with the nylon flyover.

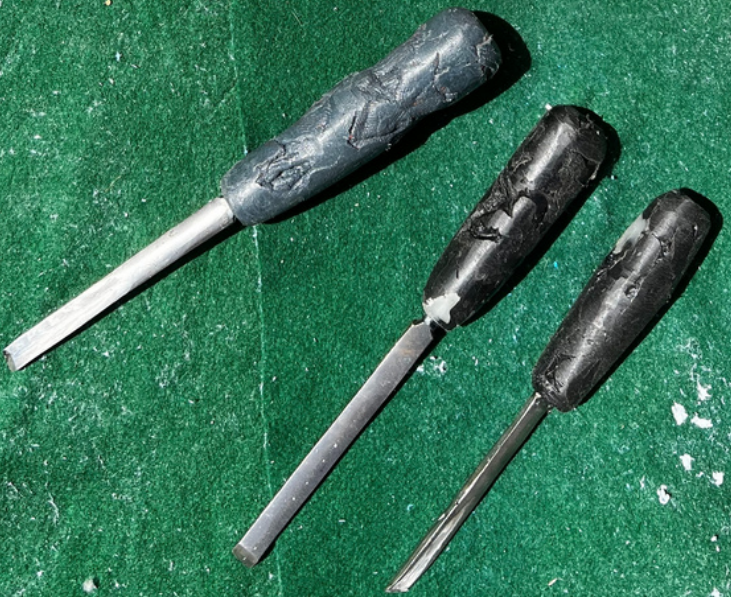

Bibliography

UN: Over 3,000 Refugees, Asylum Seekers & Migrants Lost in Sea Crossings to Europe – SchengenVisaInfo.com

URL: <https://www.schengenvisa.info.com/news/un-over-3000-refugees-asylum-seekers-migrants-lost-in-sea-crossings-to-europe/>

UNHCR WORLD REFUGEE DAY ART EXHIBITION AMMAN, JORDAN 2014. Hannah Rose Thompson

URL: <http://hannahrosethomas.com/unicef-project-jordan>

Education Events – THE WALK.

URL: <https://www.walkwithamal.org/education/education-events/>

Palestinians With Keys To Their Homes: Can They Ever Go Back? – I Love Muslims. Mark Vanderput.

URL: <https://ilovemuslims.net/2017/06/palestinians-with-keys-to-their-homes-can-they-ever-go-back/#>

Free as a bird: How pigeons have become a source of solace for Jordanians in lockdown. The National News. 22nd June 2022.

URL: <https://www.thenationalnews.com/lifestyle/wellbeing/free-as-a-bird-how-pigeons-have-become-a-source-of-solace-for-jordanians-in-lockdown-1.1025513>

Music Festival Waste Public Insights. Play By Decathlon.

URL: <https://play.decathlon.co.uk/articles/music-festival-waste-public-insights>

‘THEY ARE ONE OF THE WORST THINGS TO TRY AND RECYCLE’: TENTS LEFT BEHIND AT READING FESTIVAL SPARK ENVIRONMENTAL CONCERNS. Independent Olivia Petter, 1st sept 2021.

URL: <https://www.independent.co.uk/climate-change/sustainable-living/reading-festival-tents-left-behind-climate-b1912462.html>