

ϕ

dell y deacon



















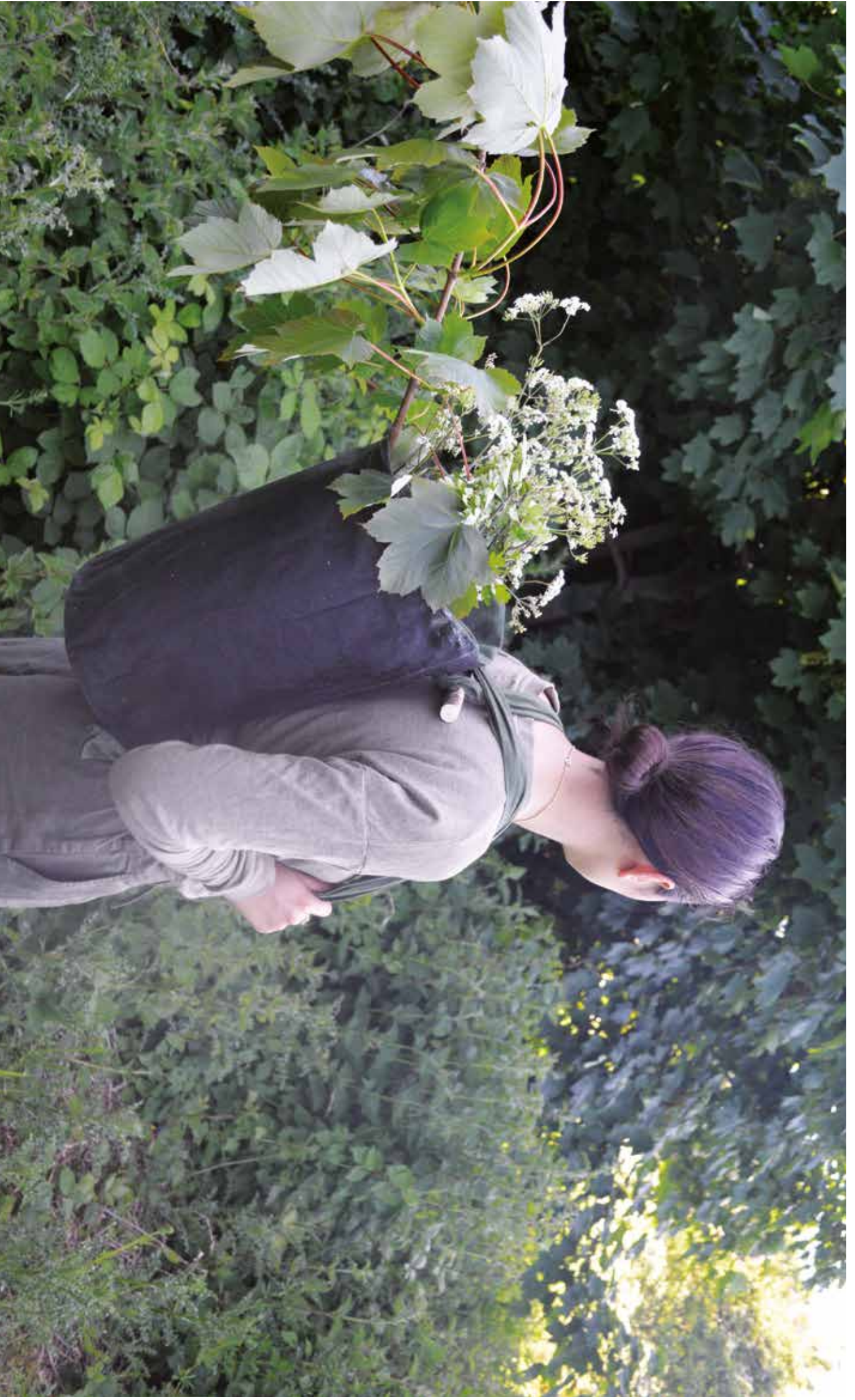





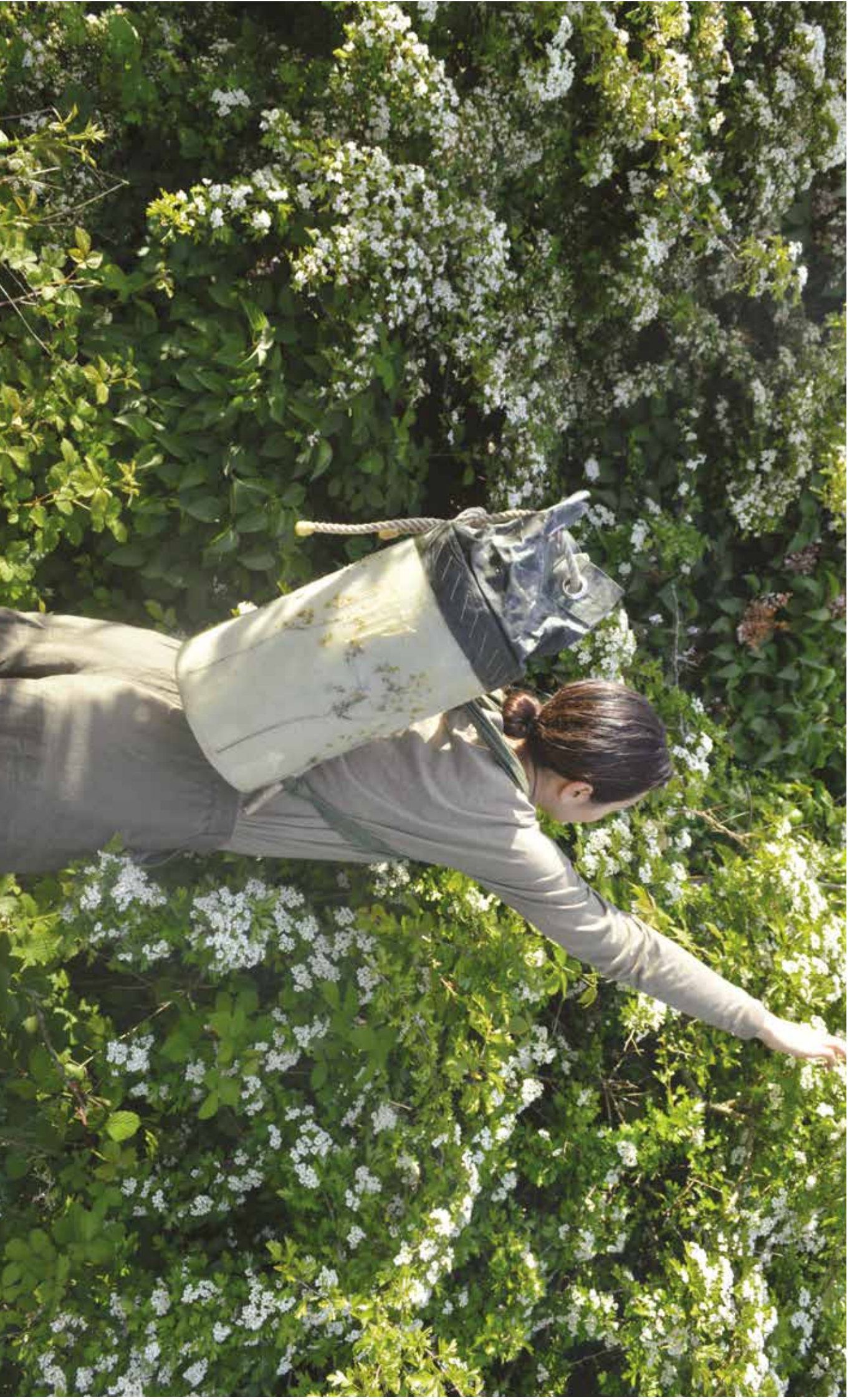



















the backpack

Aug. 19, 1924.

1,505,661

L. F. NELSON
PACK
Filed July 31, 1922

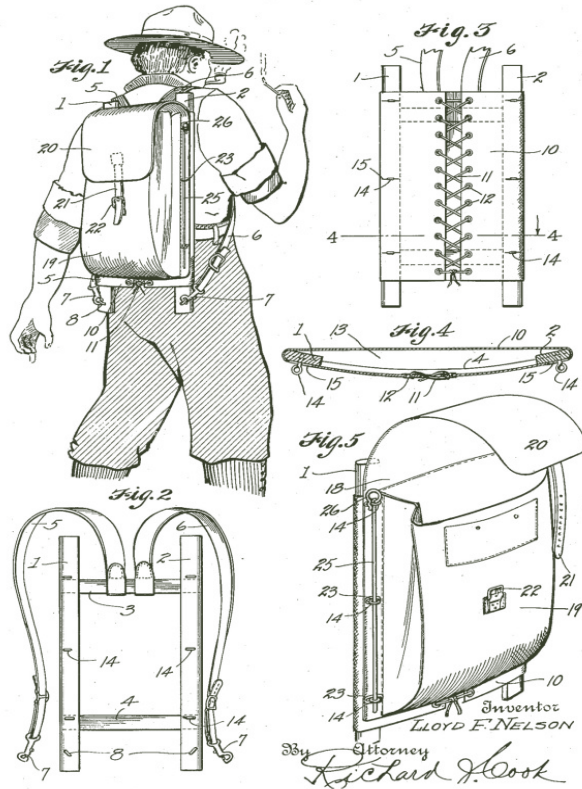



Marchand de poteries. Spa, début du XIX^e siècle.
D'après un dessin de Joseph Body.
Archives du Musée, N^o 17291/3311.



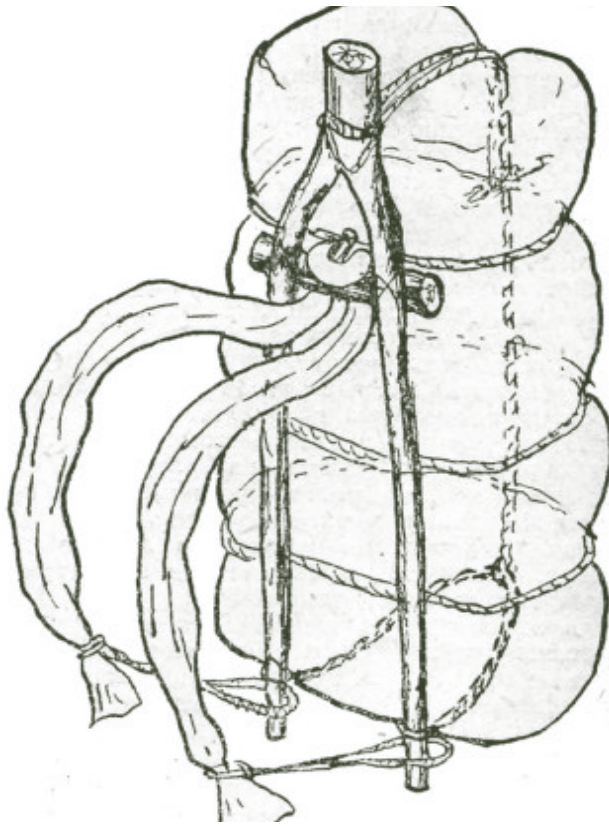
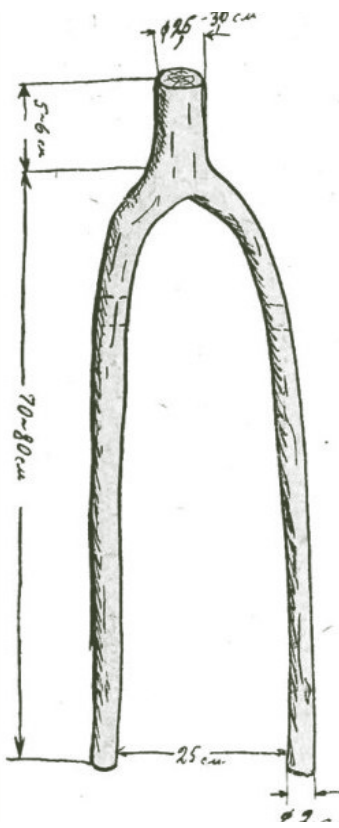

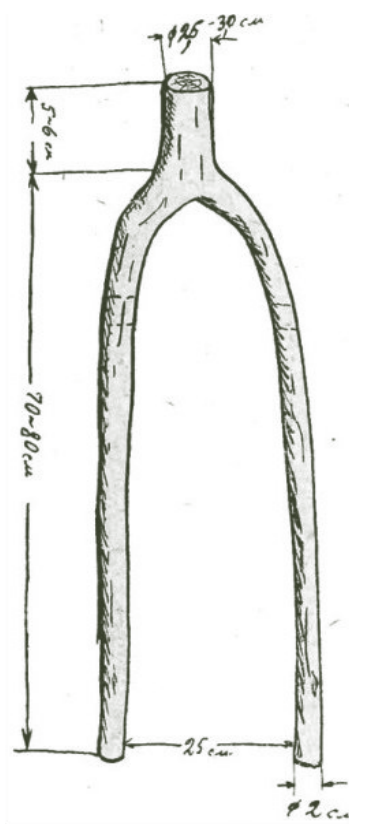
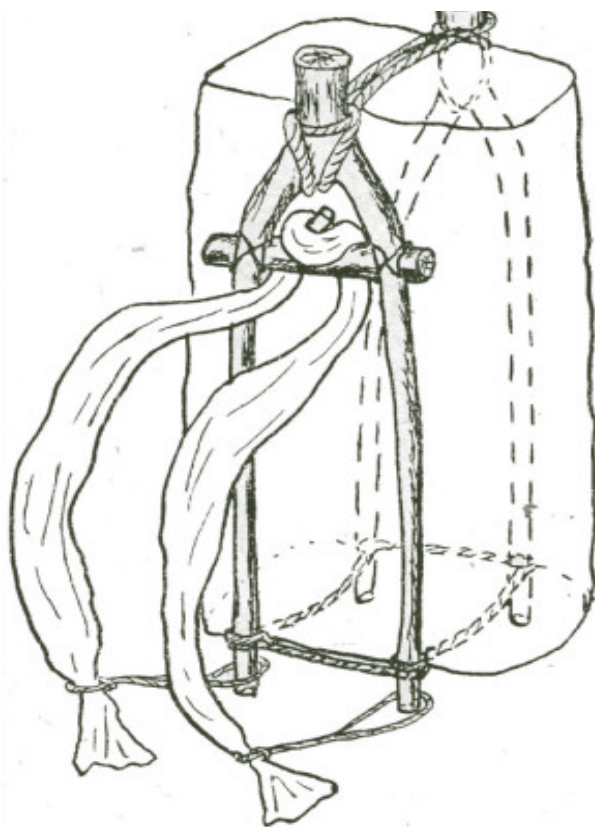























LXXII.

Ein Weib auf dem Frankenland.

Ein Fackel von Tabak und Harz/
Wann sie mit gehen an den Markt.

Und ihren Ofen kaufen ein/
Zeit sie mit ihrer Arbeit rein.

21. 9



Fig. 189.—“Oysters in the shell!”



Fig. 204.—“Cottrets !”



Fig. 218.—A milkmaid.









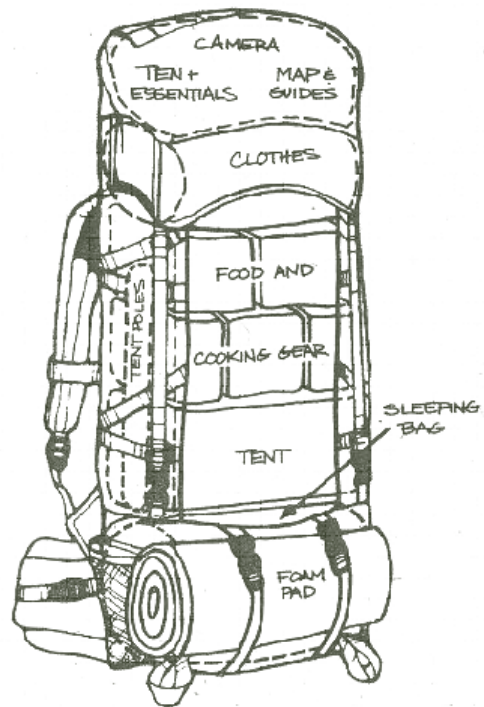

*Collected
objects*

































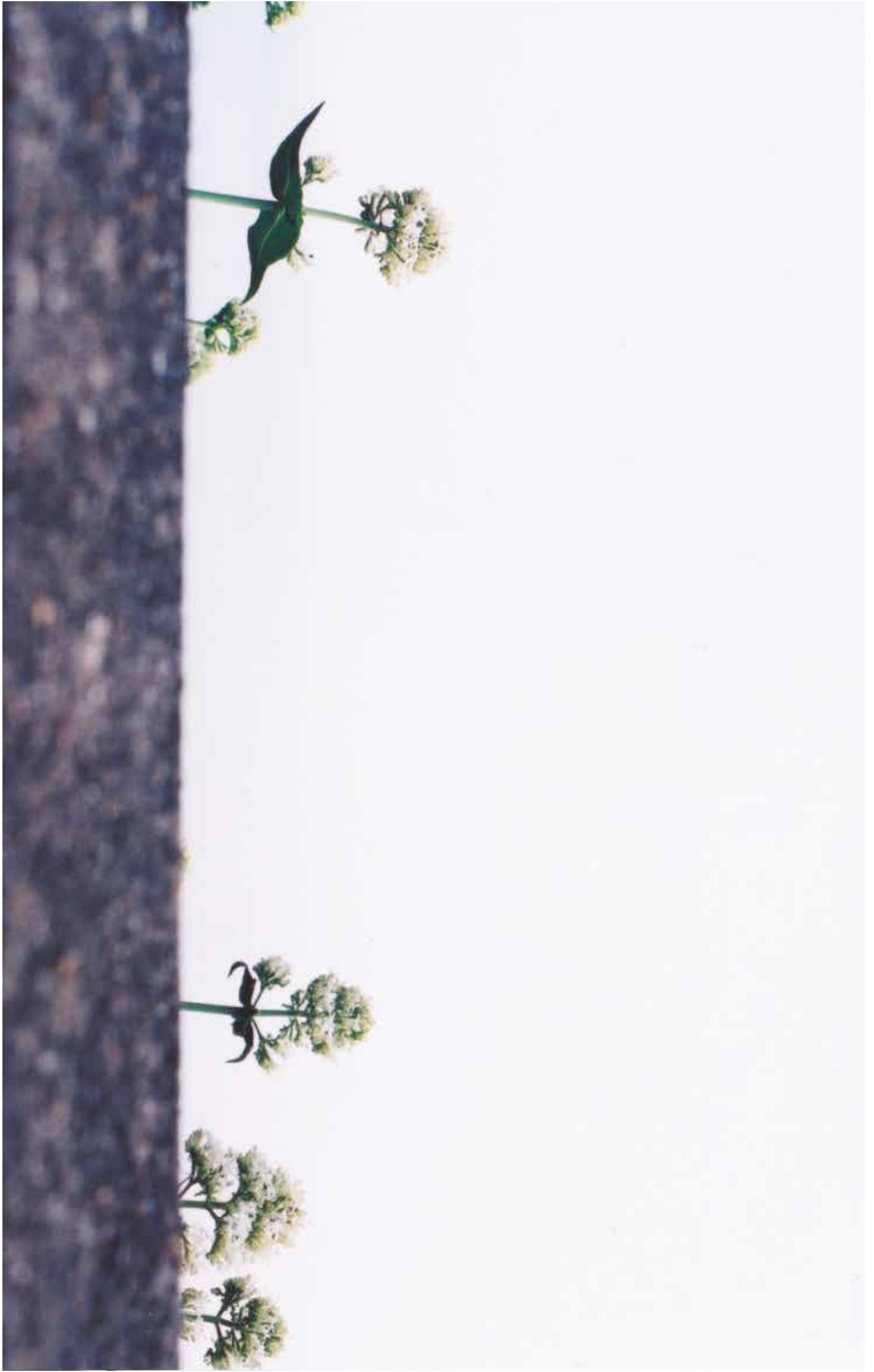







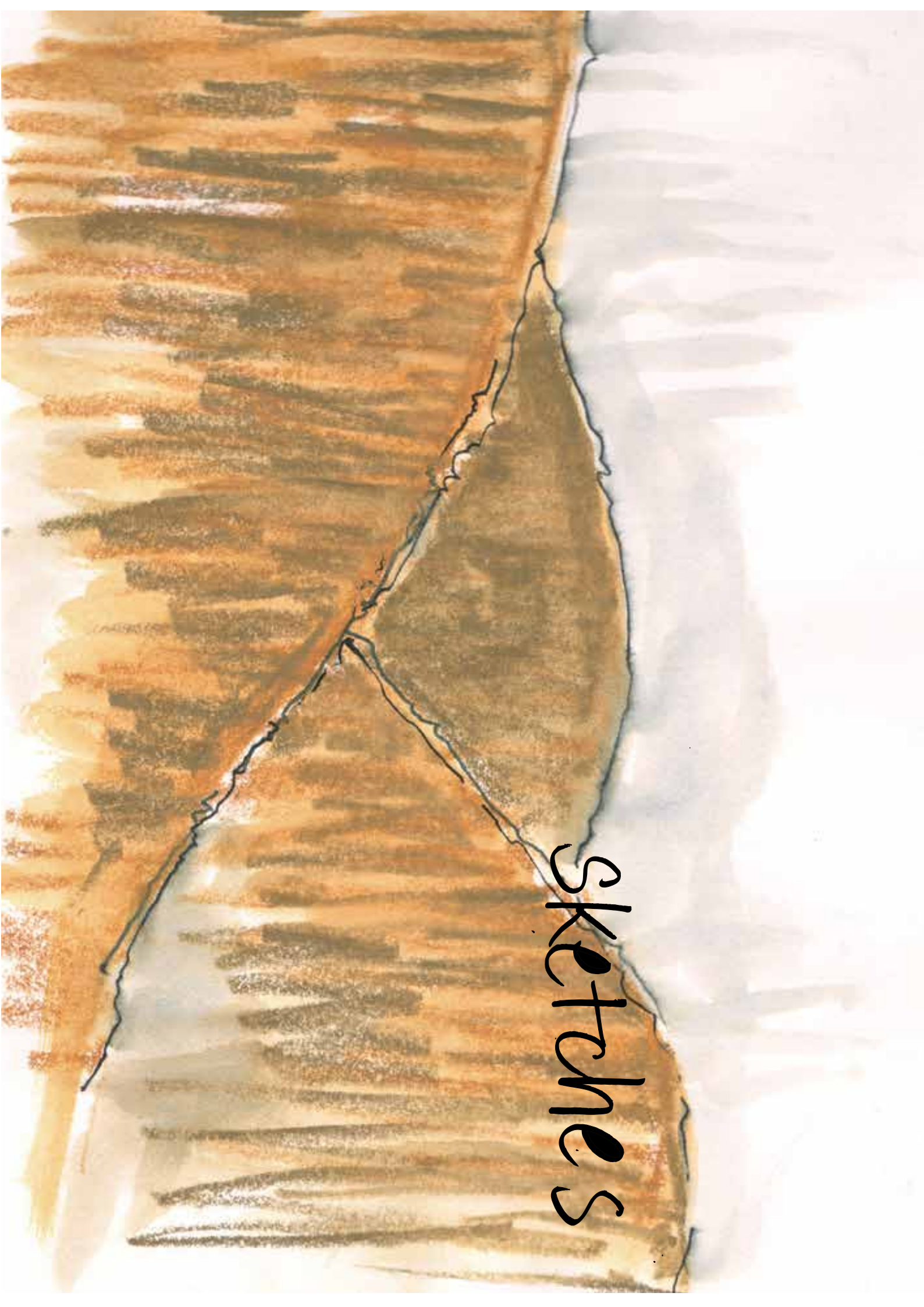

sketches



patshwolk
tent.

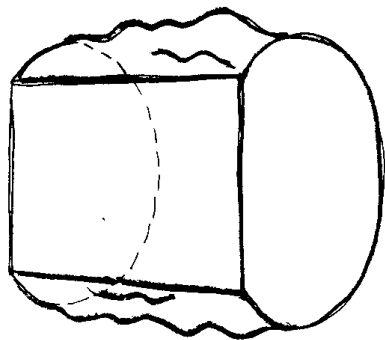
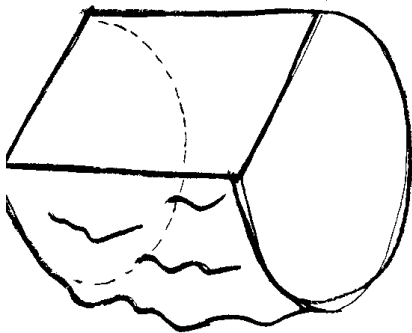
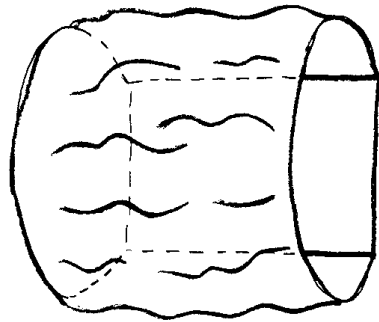
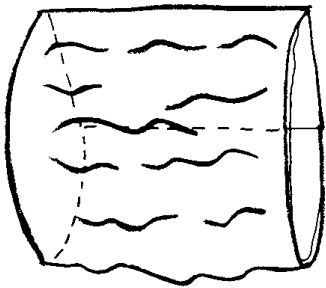
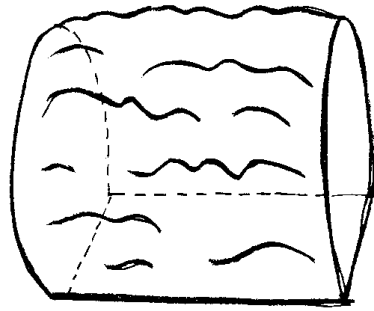
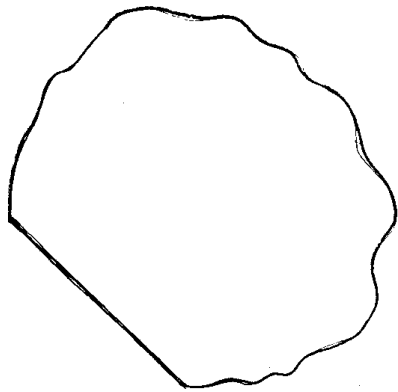

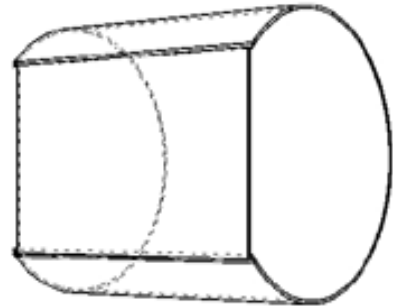
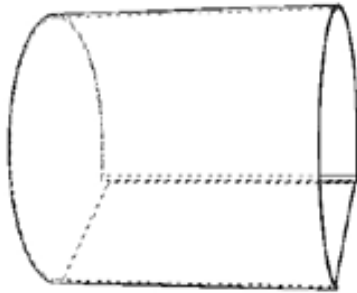
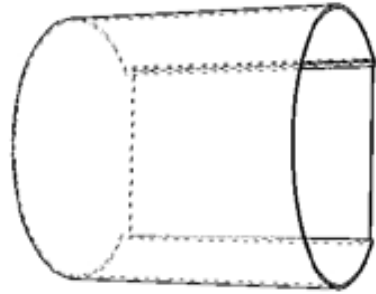
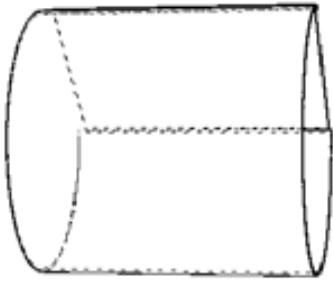
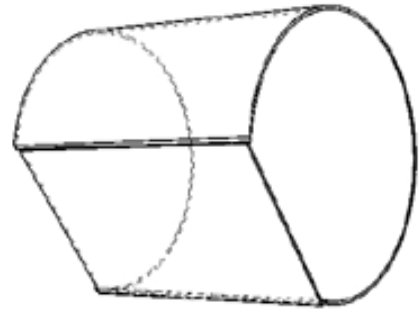

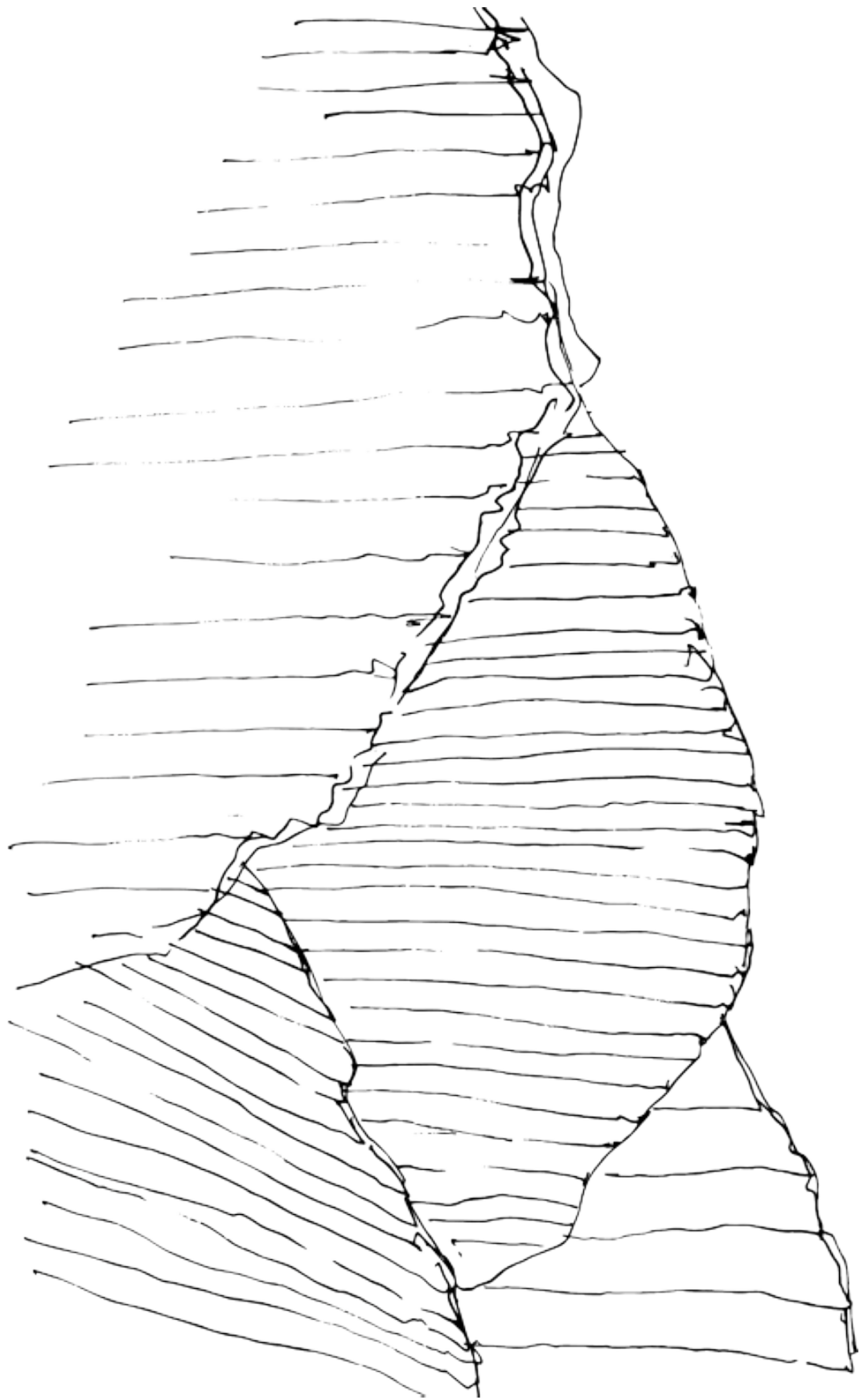

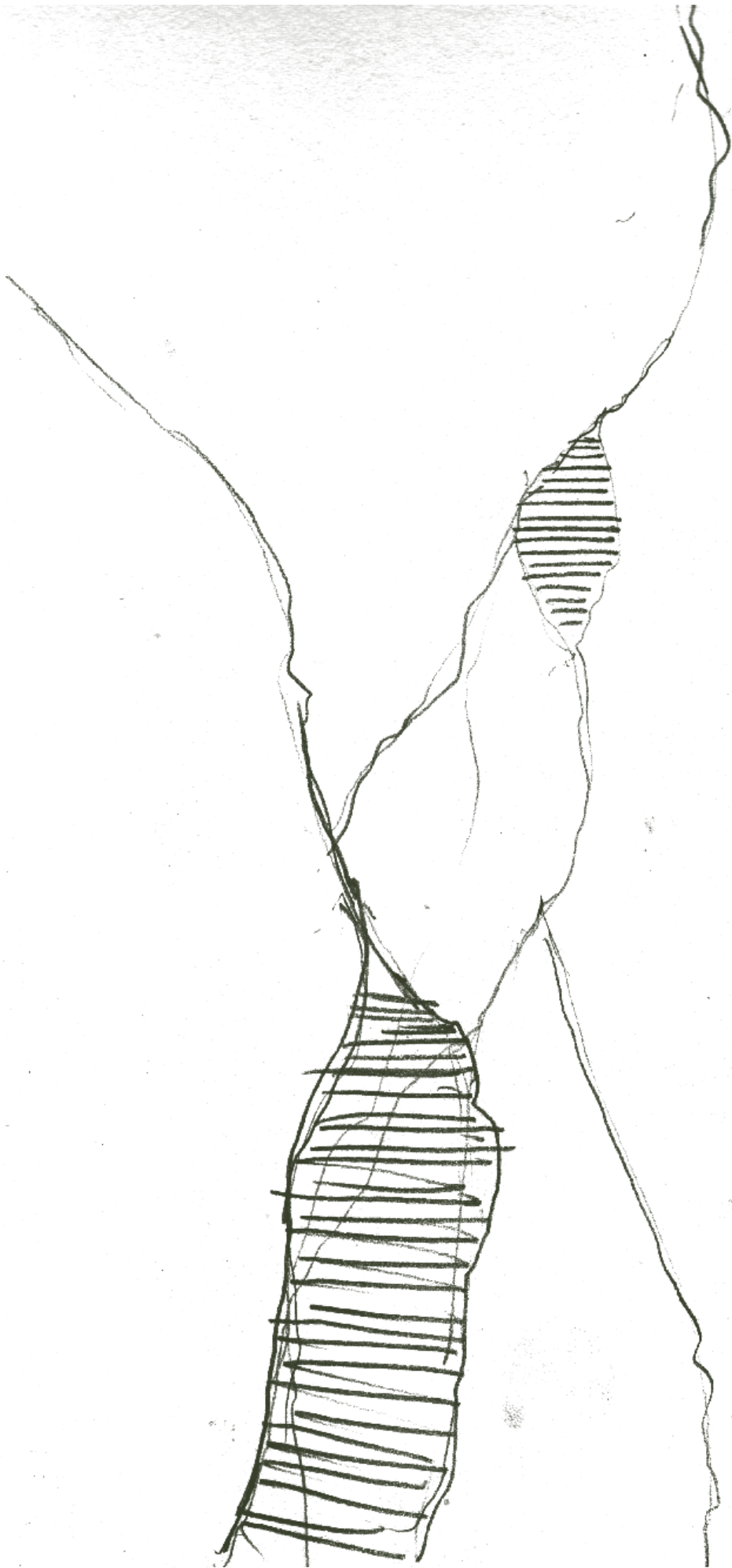

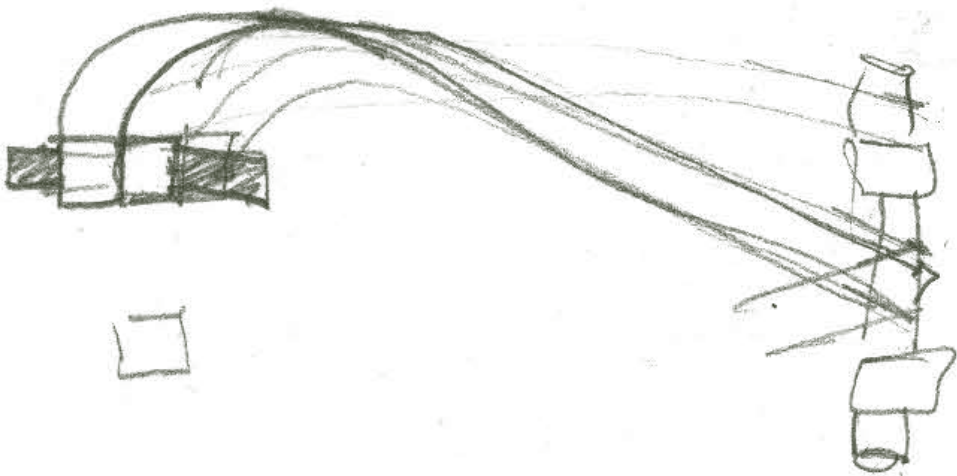
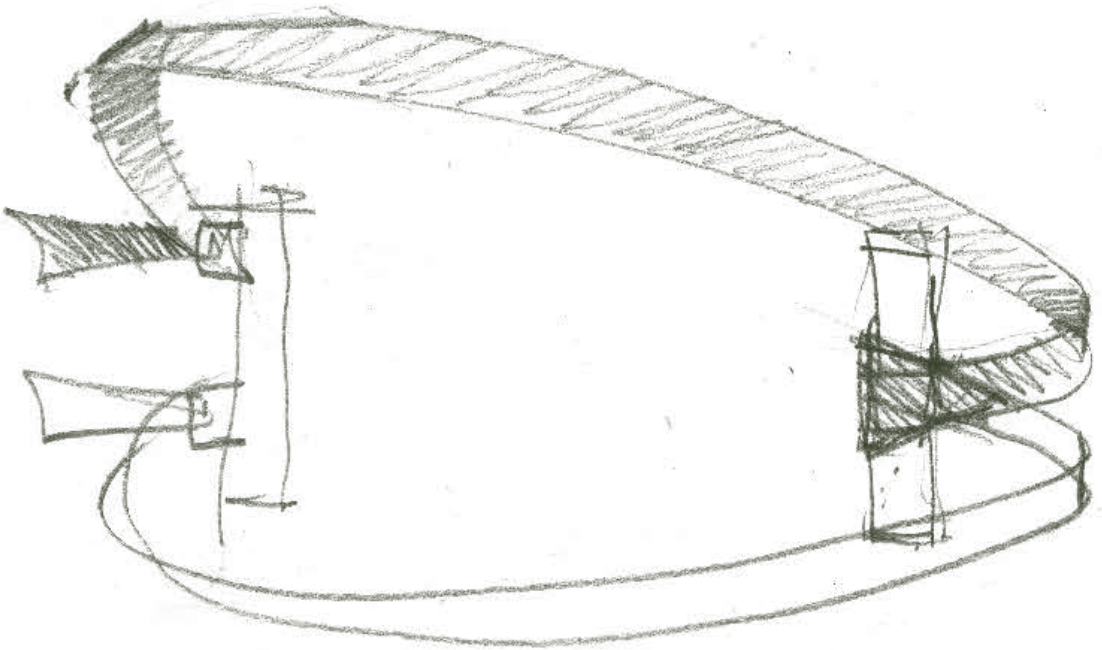
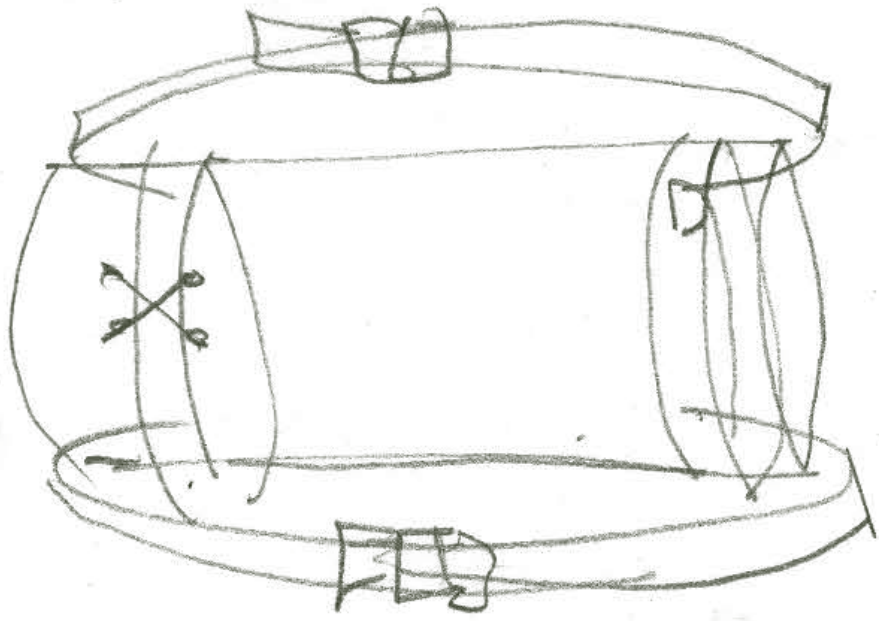

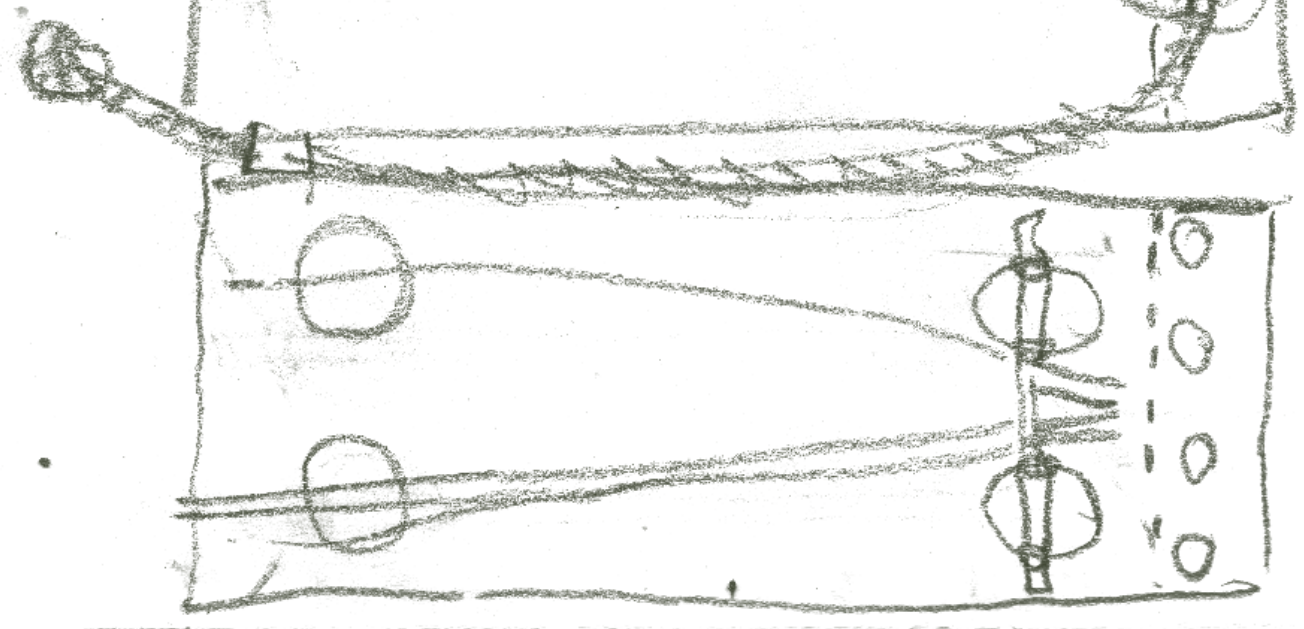
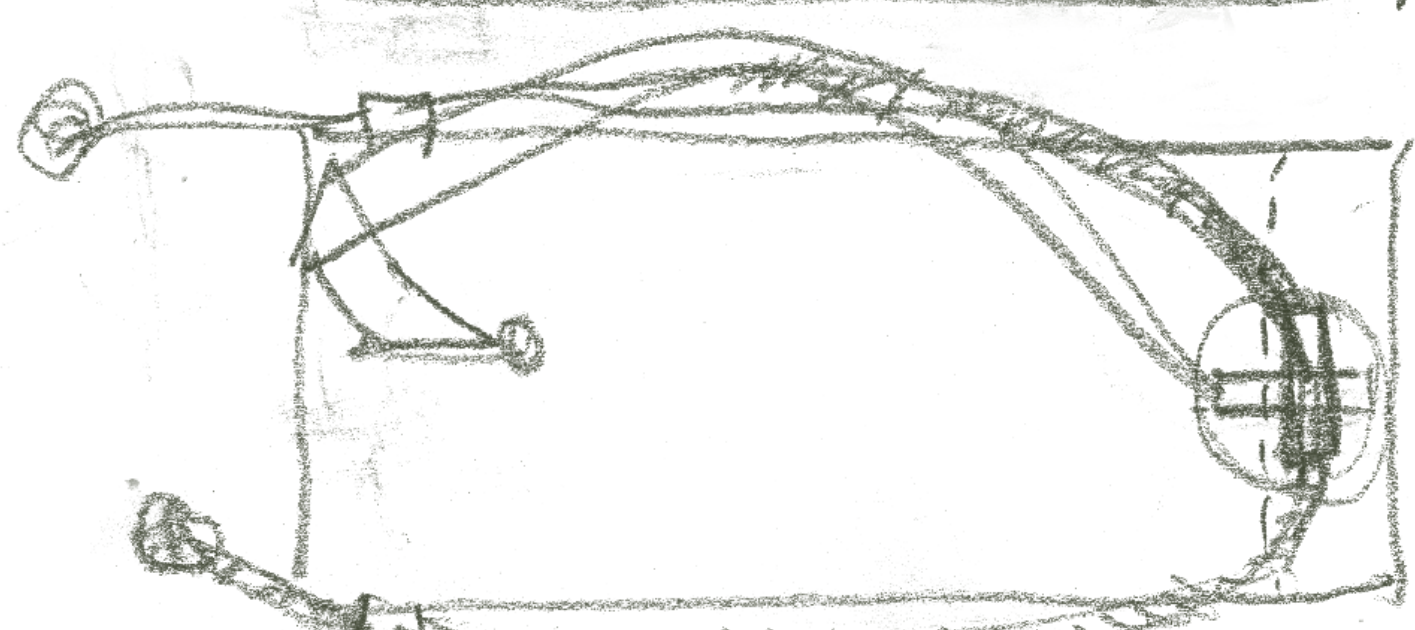
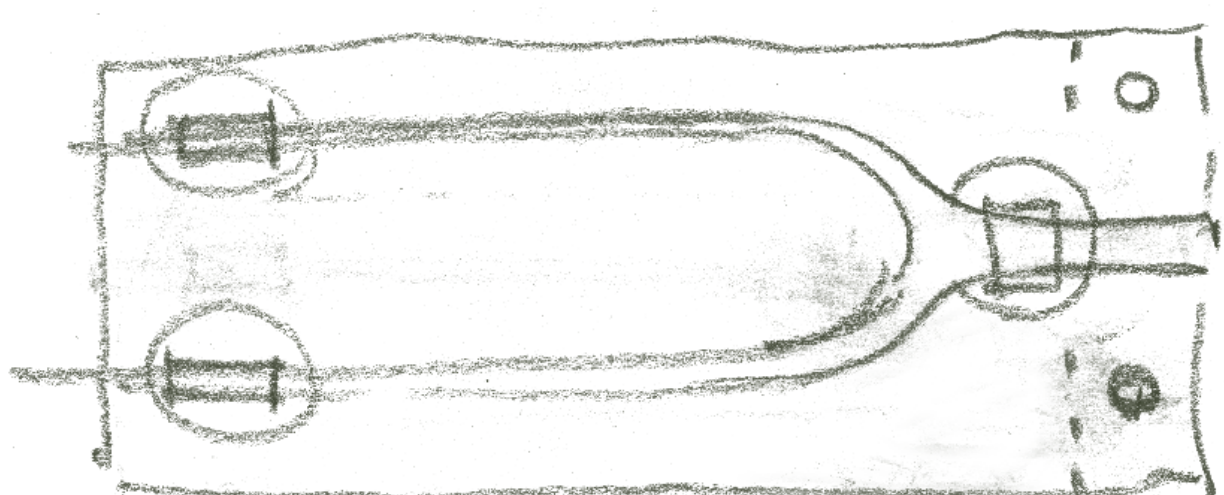
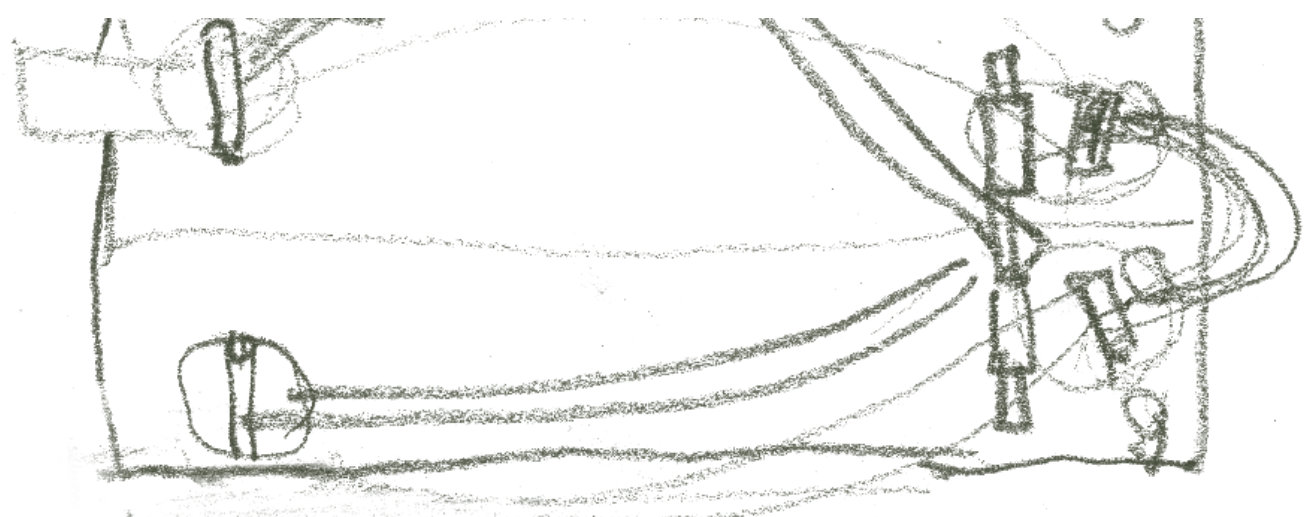

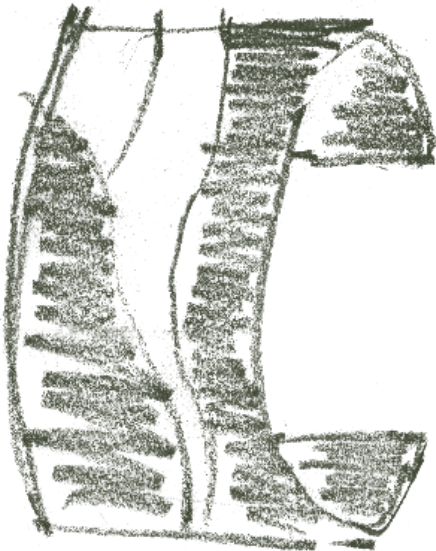
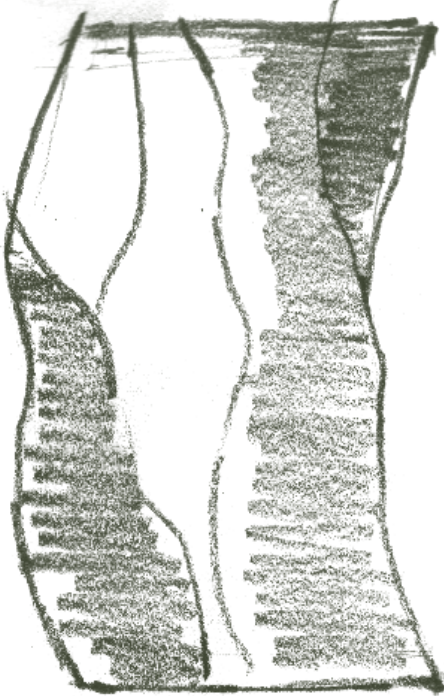

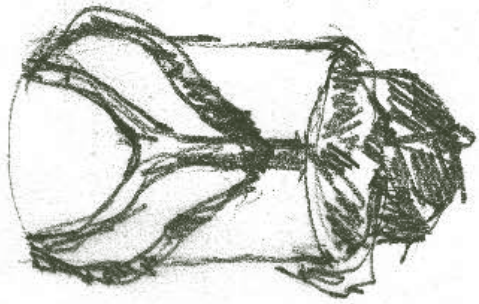
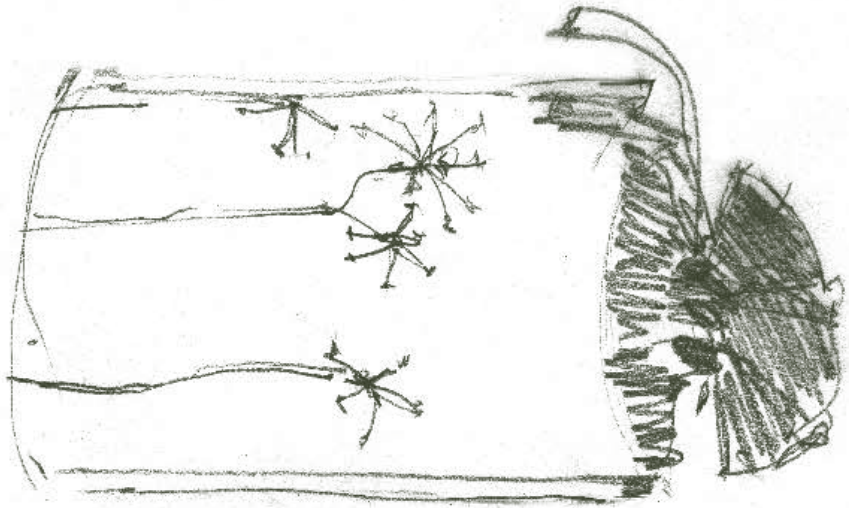

flower
vesse |

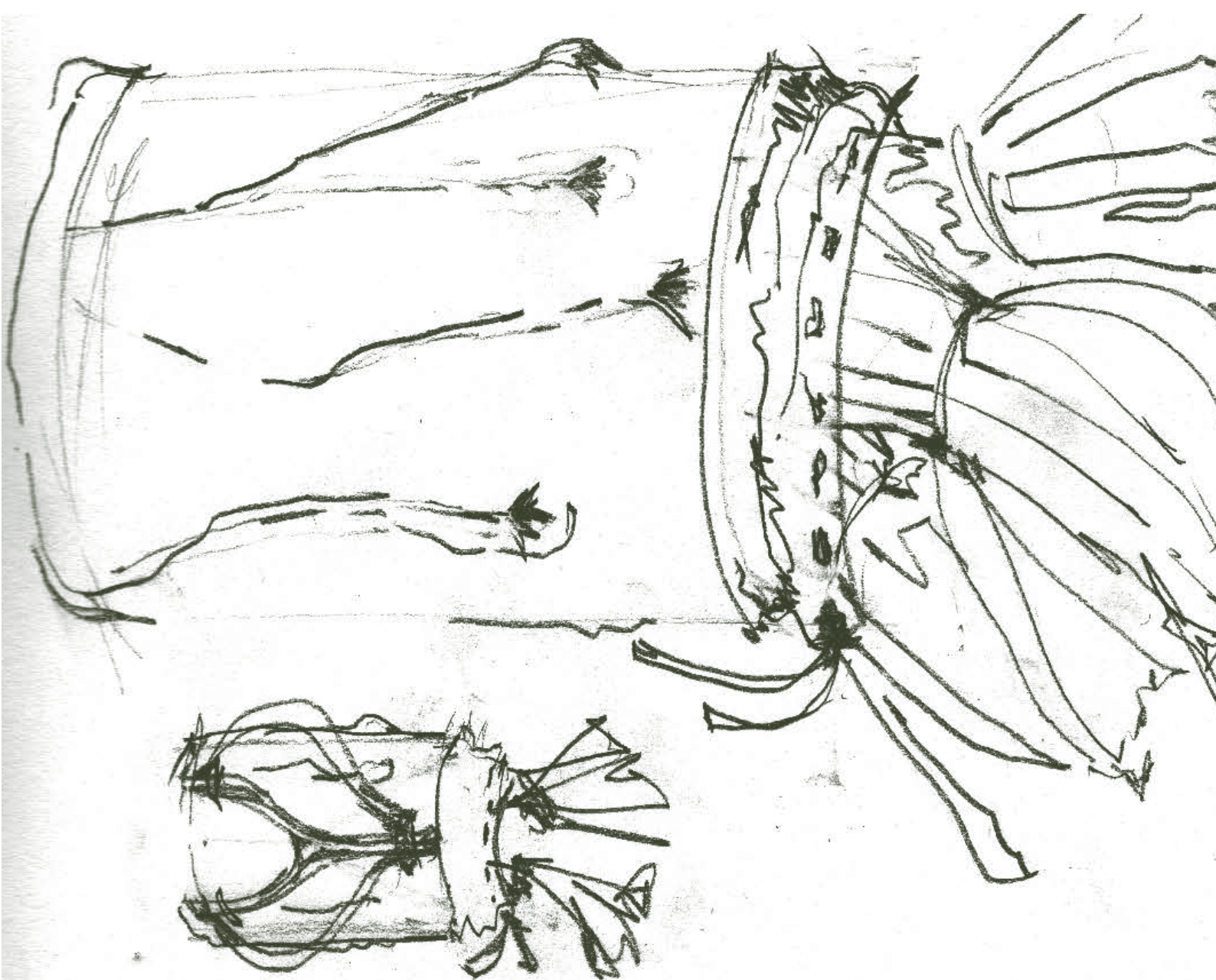

The giant vessel.

Arrows showing
beeswax top →

Solid resin
back vessel →

Plant within
the resins
layers -
can be aged

fabric
base →

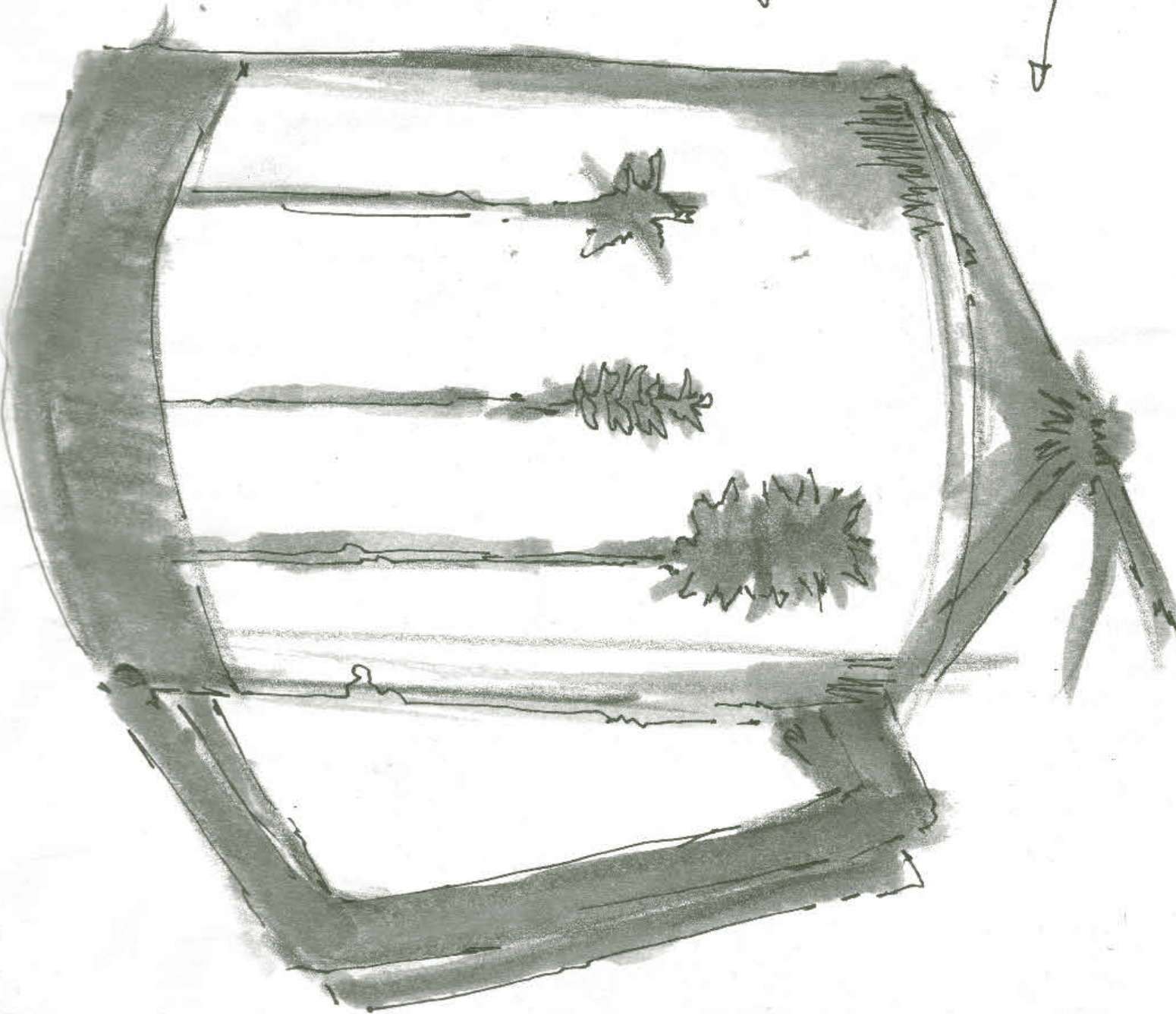

fresh plants

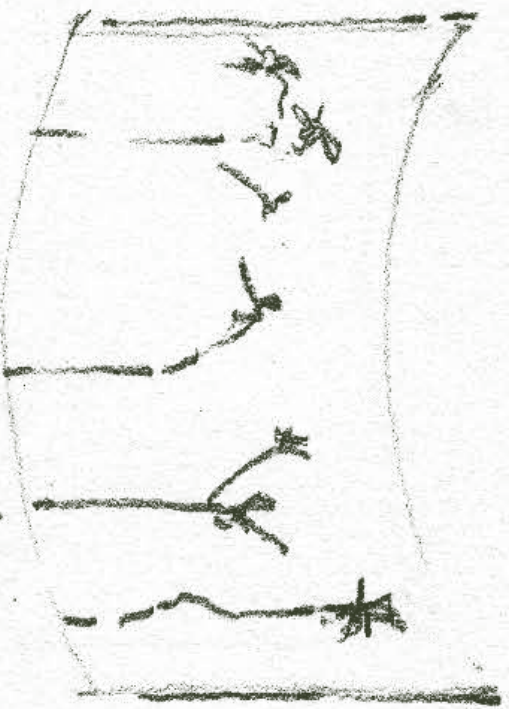

twisted copy



photocopied plants

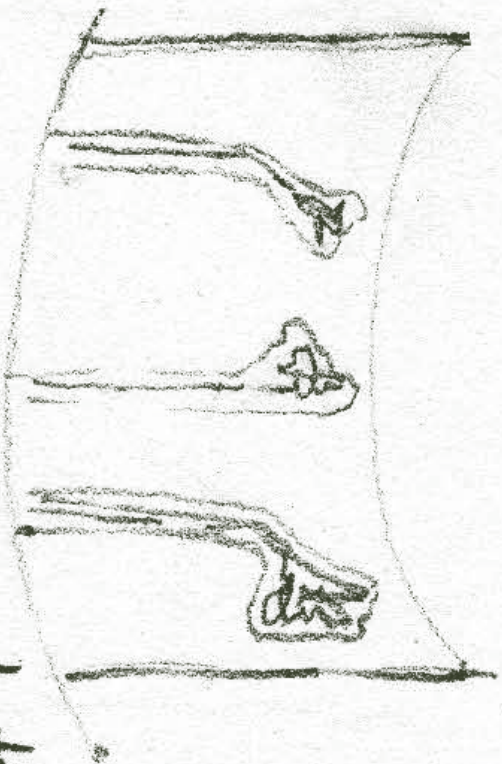

soft down's





3D milk?



map with walk



2D milk



chalk
milk
ps?

width

45m?

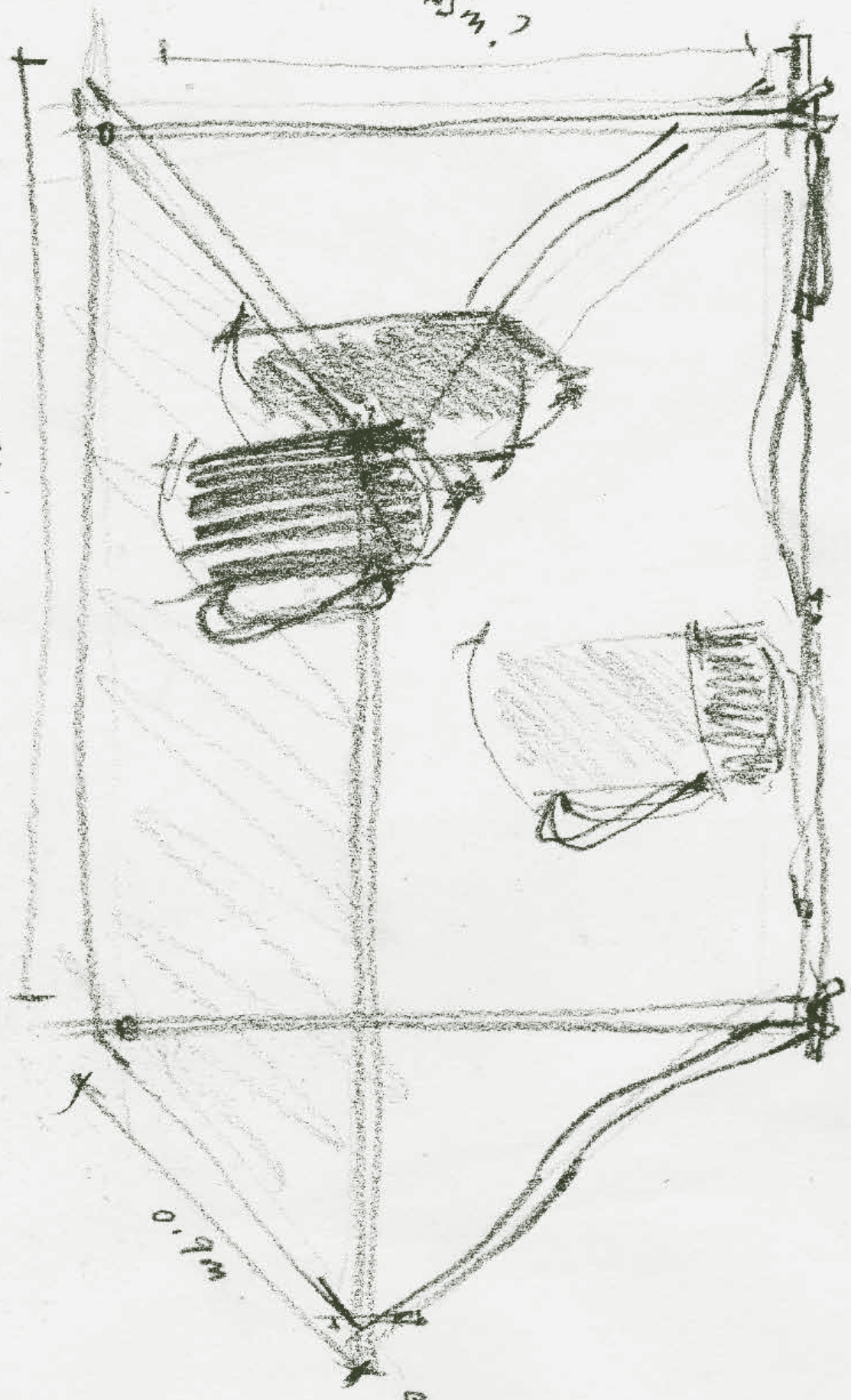

0.9m

2m long side

Wap
+ part

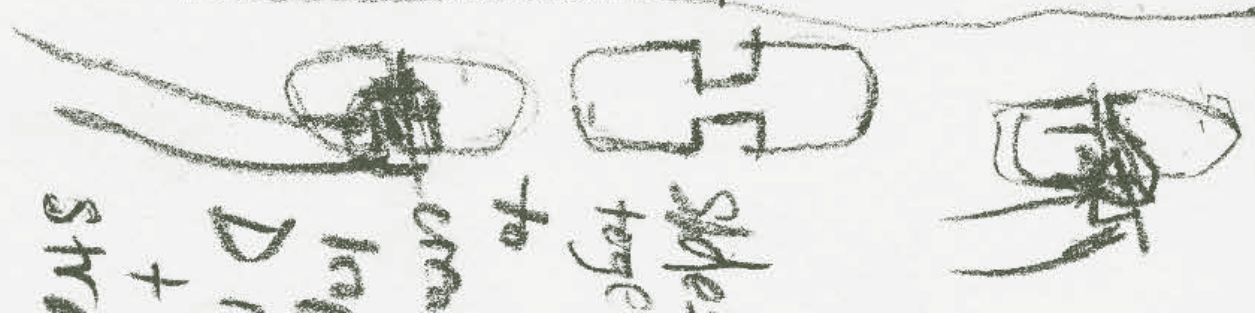
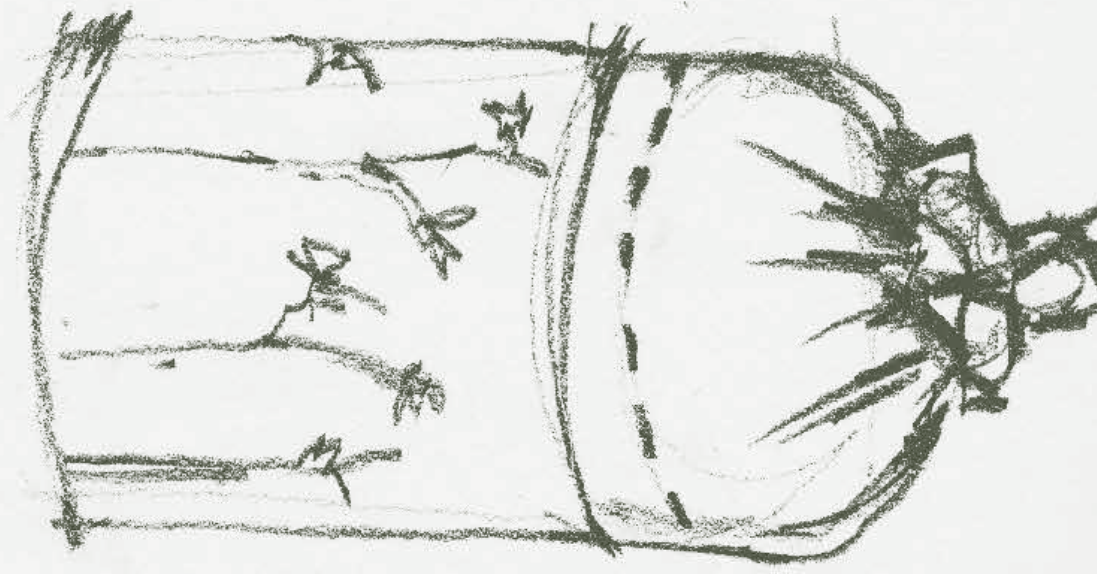

side
to
D
+
str

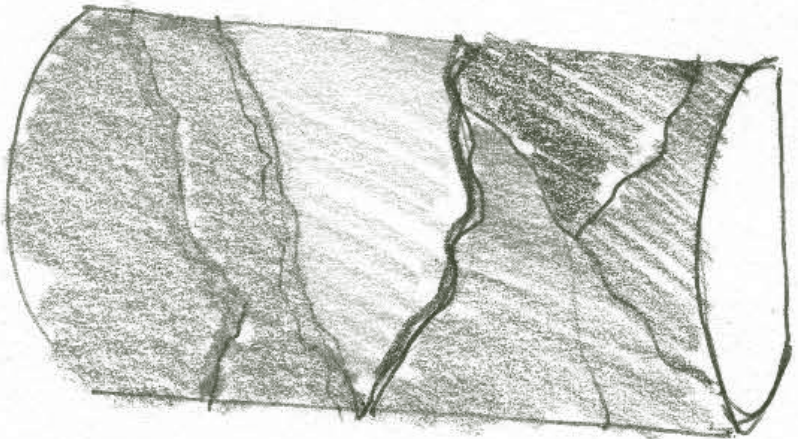
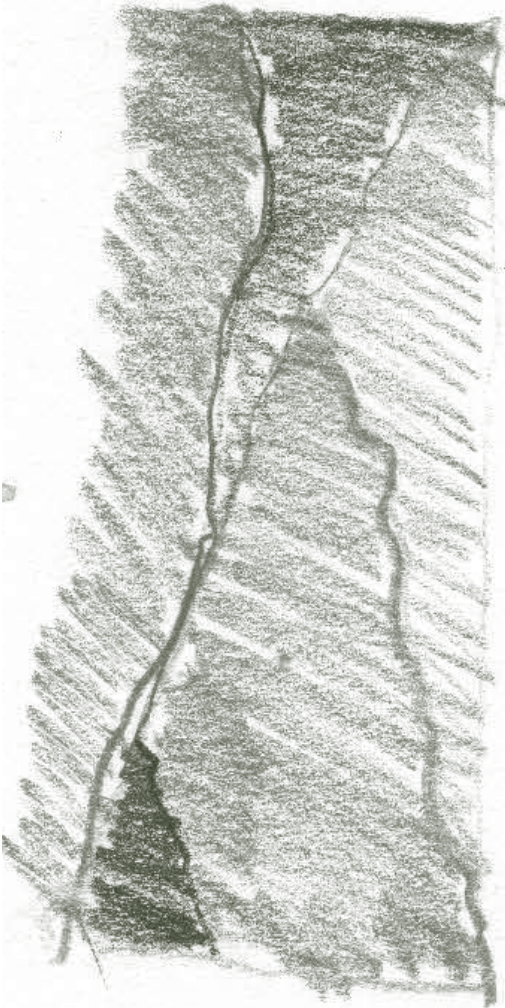
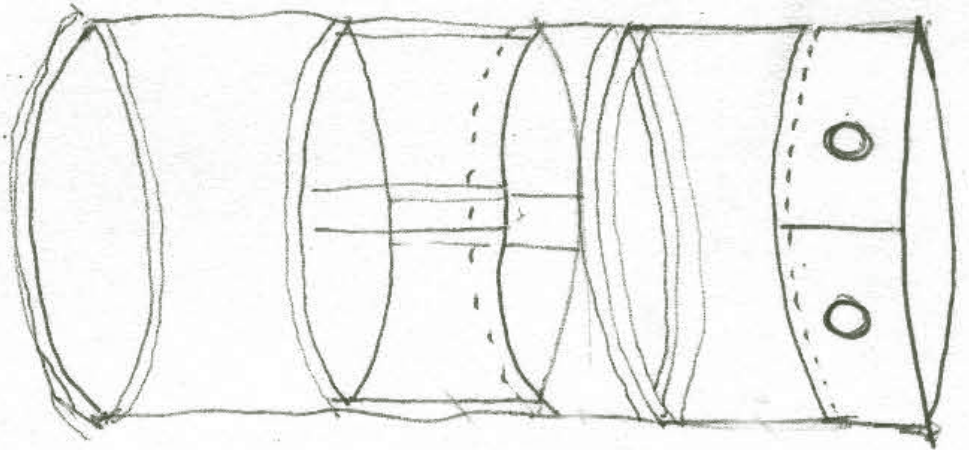
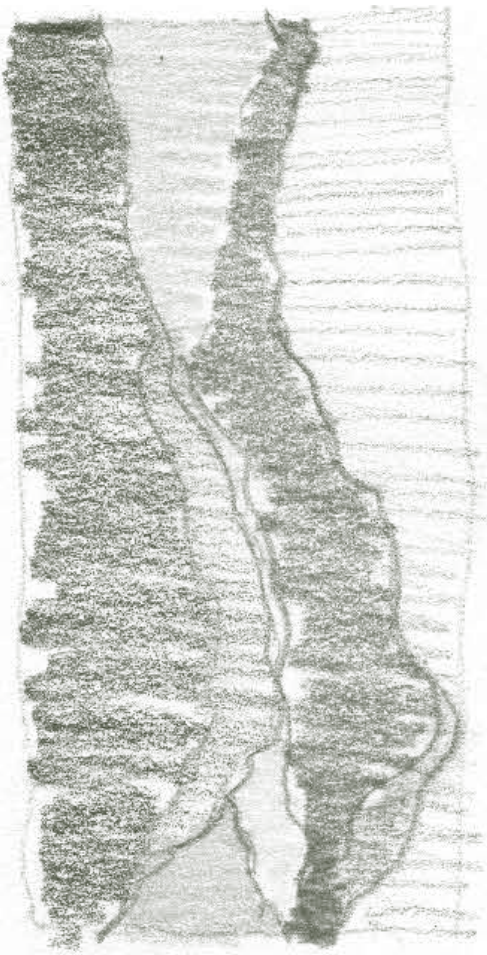

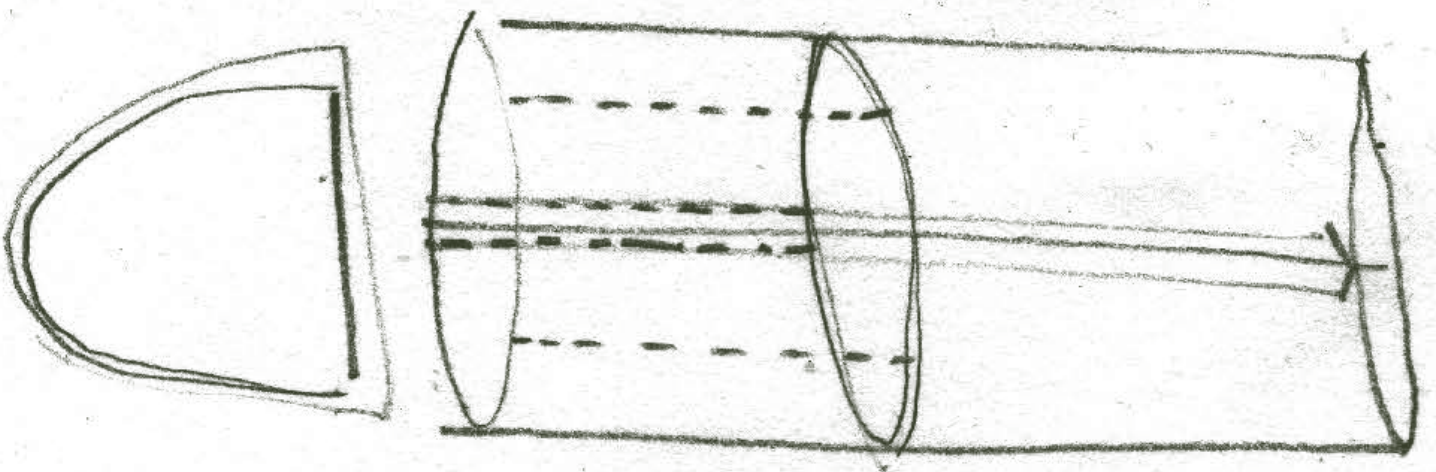
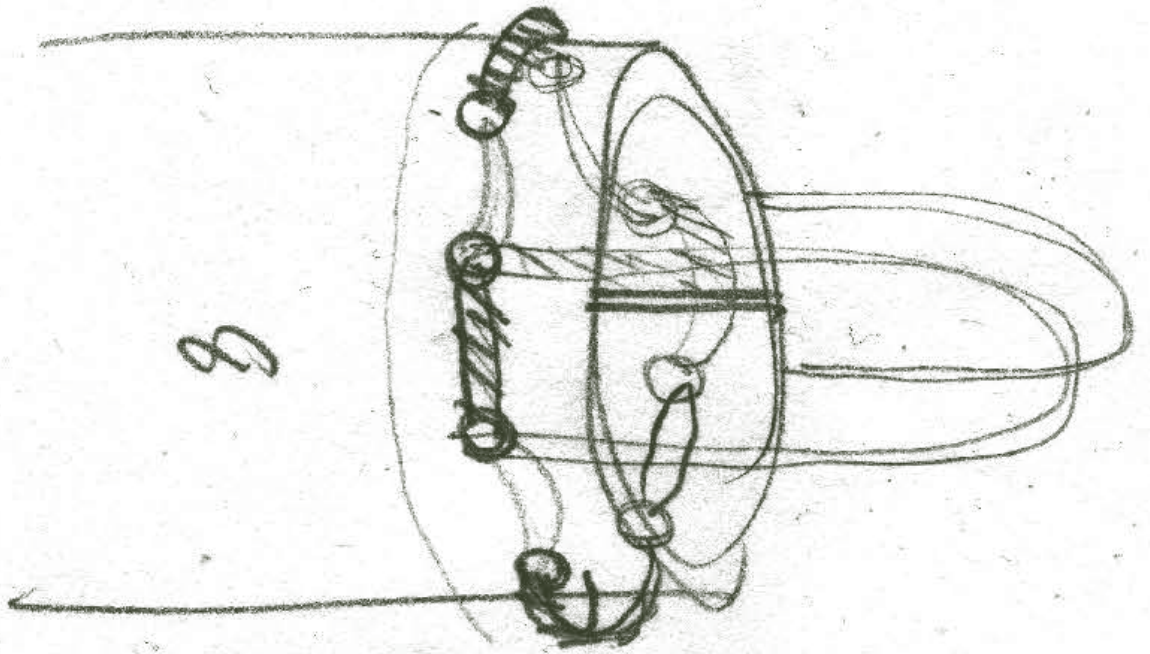
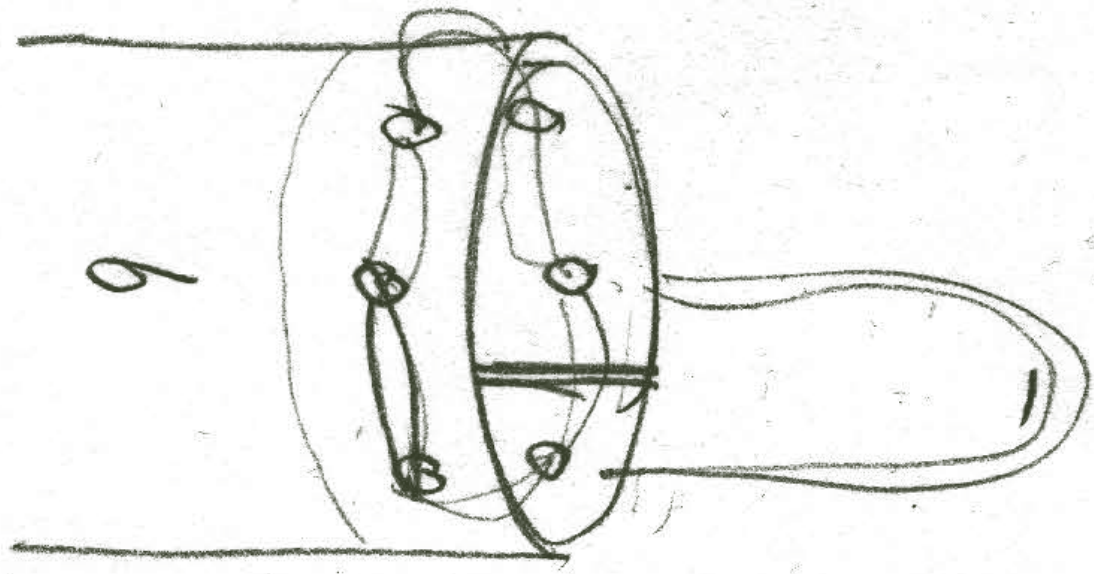





map vessel

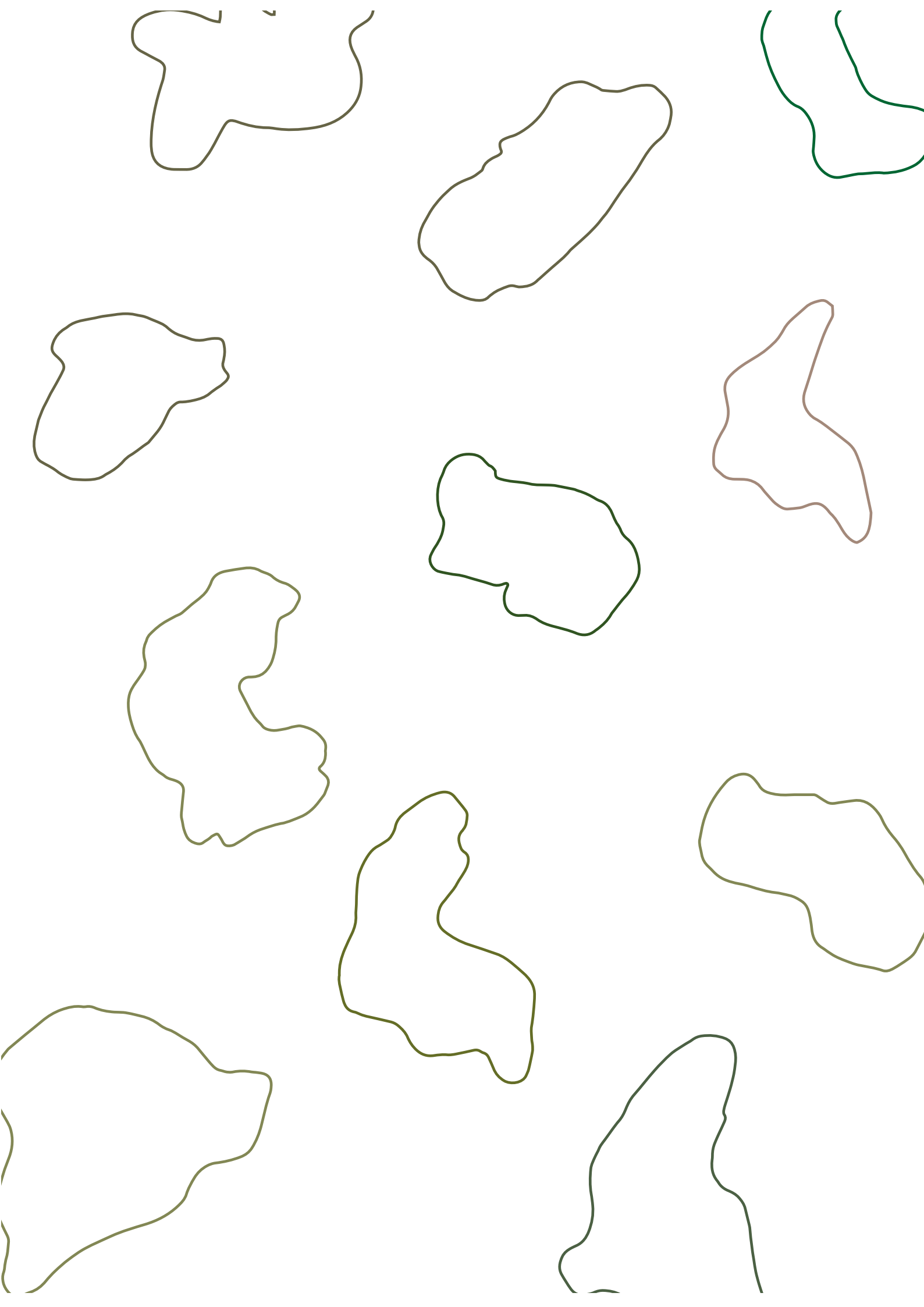

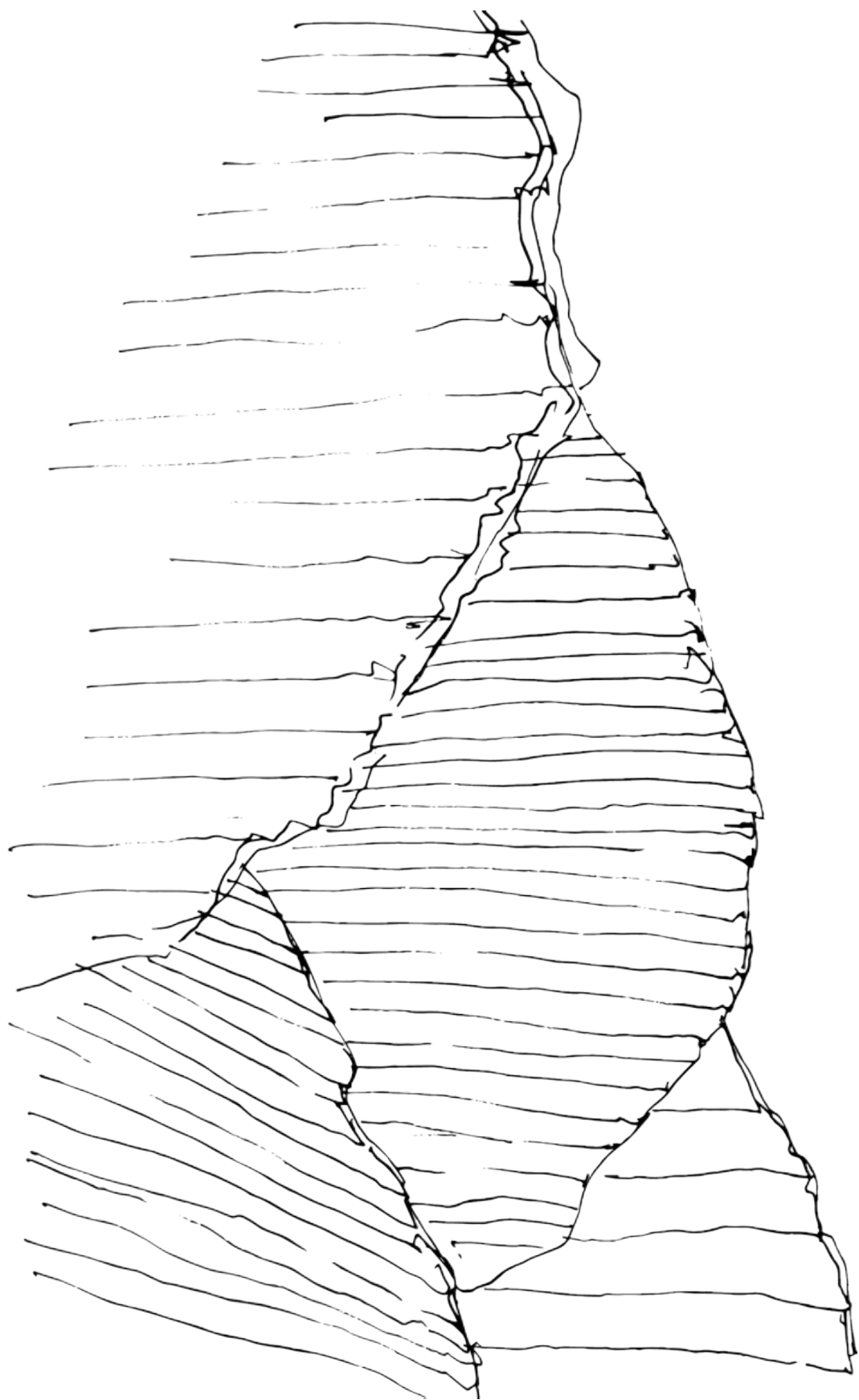

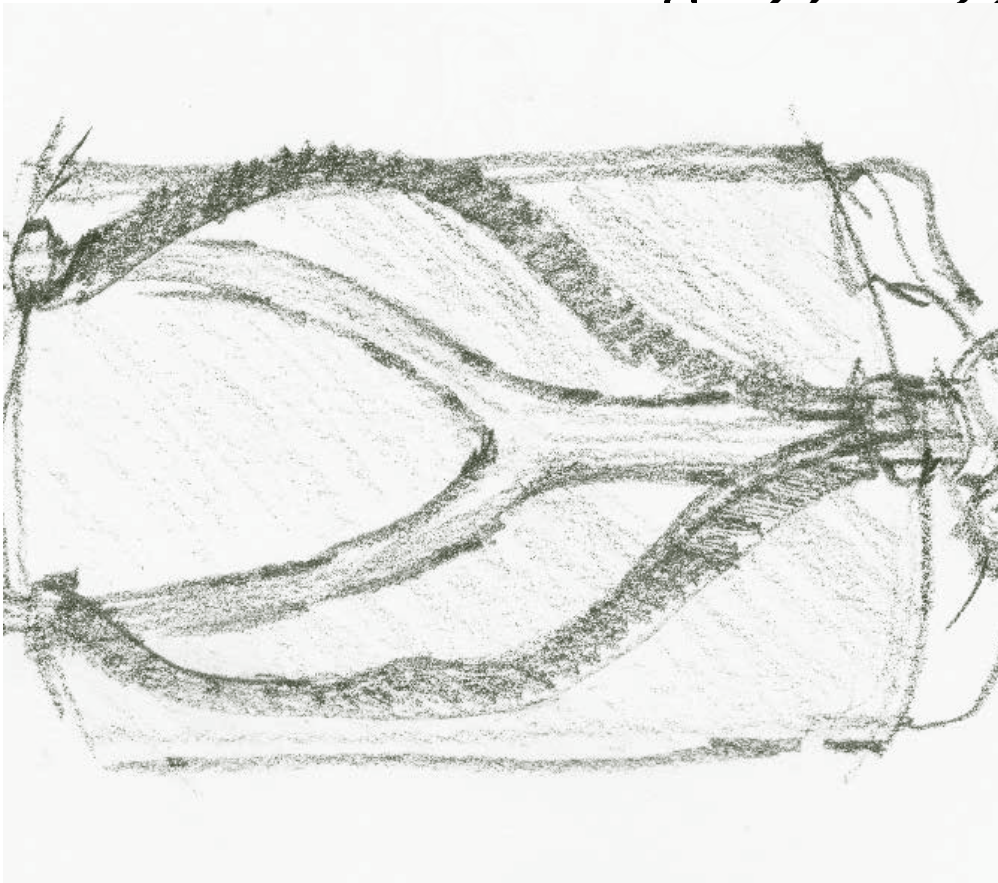
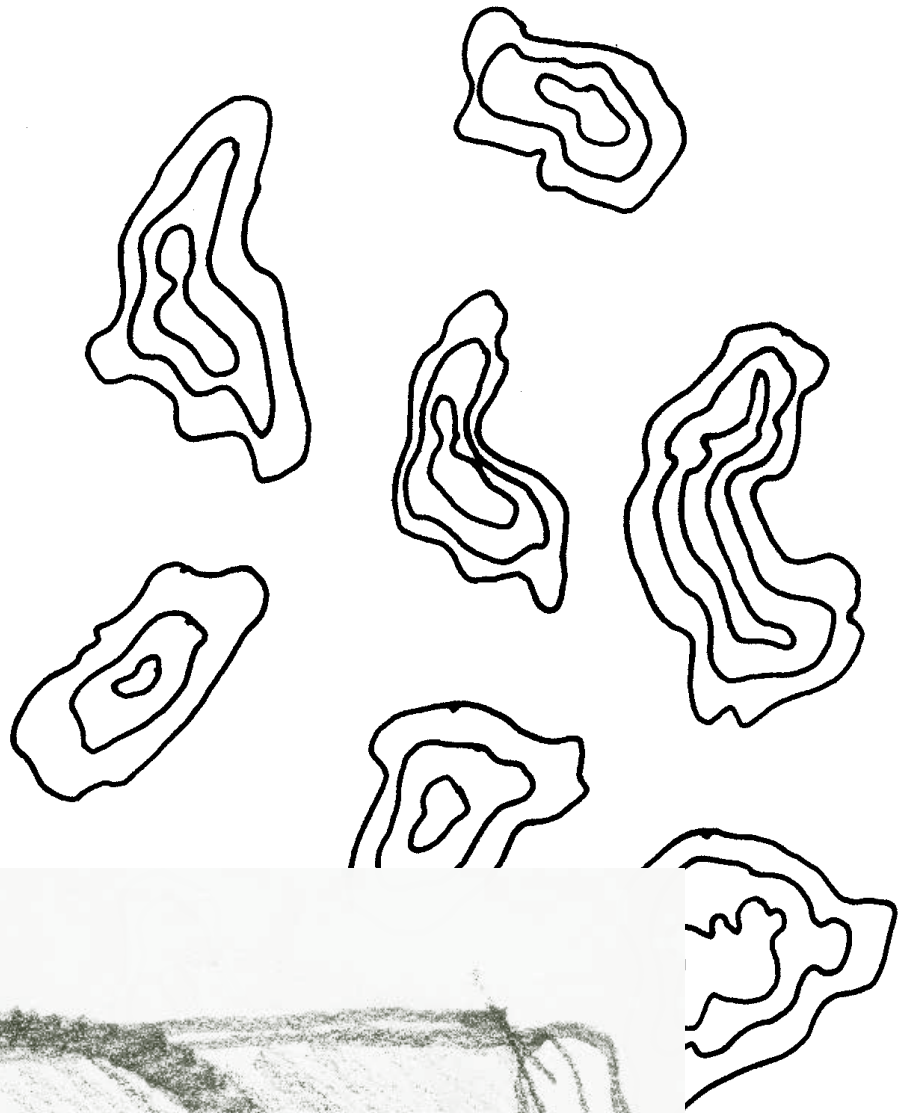

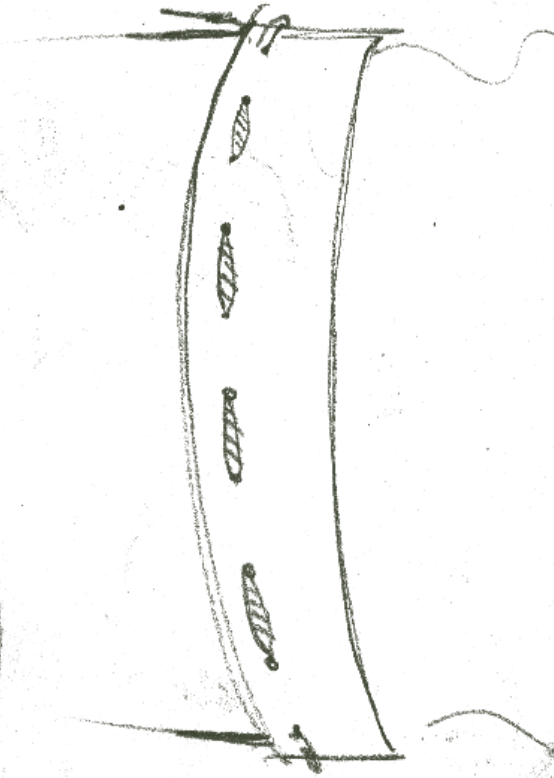
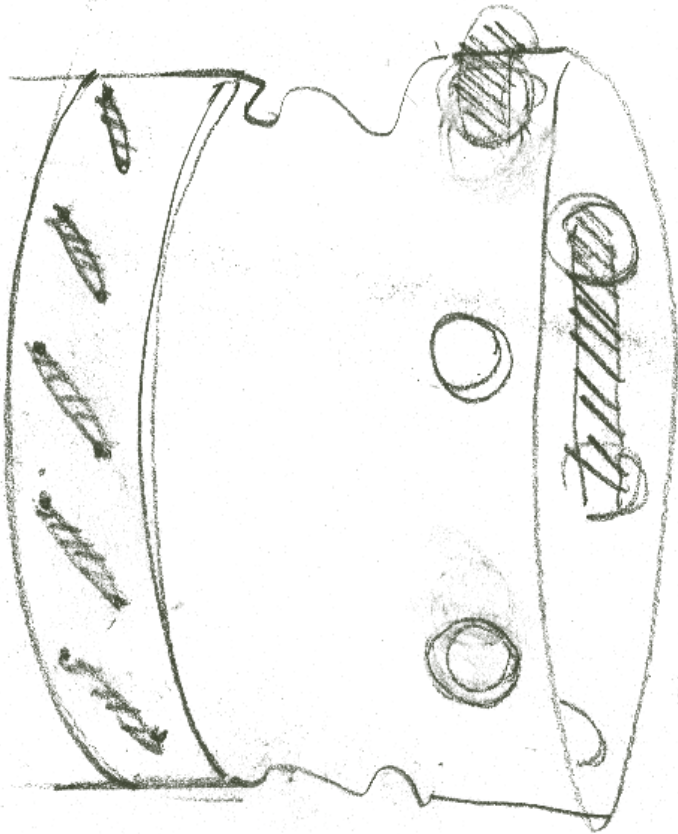
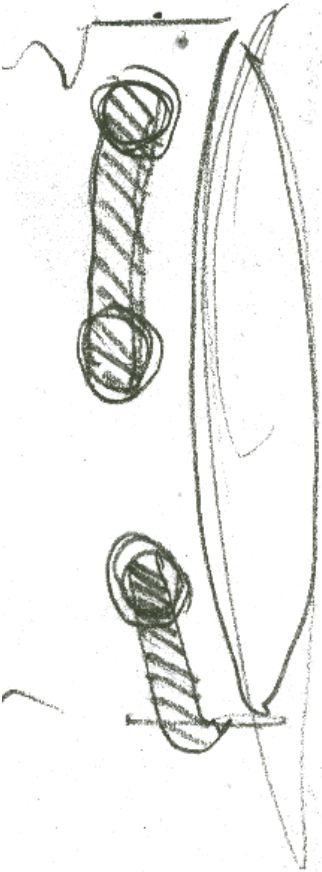

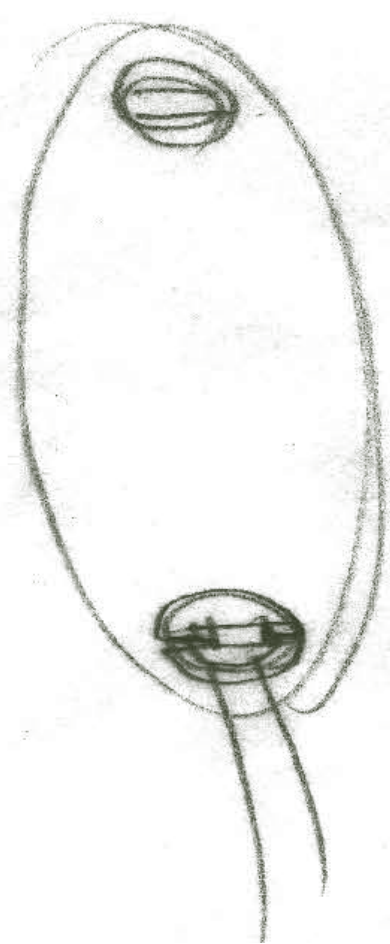
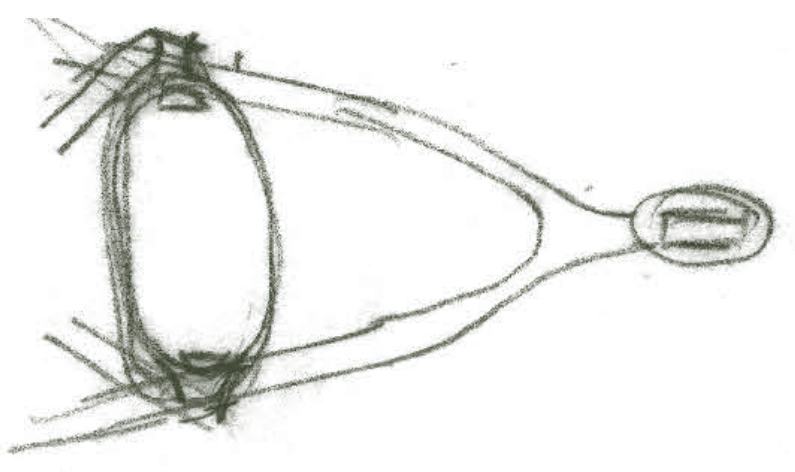

layering -
lay up resin
with leaves

waxed

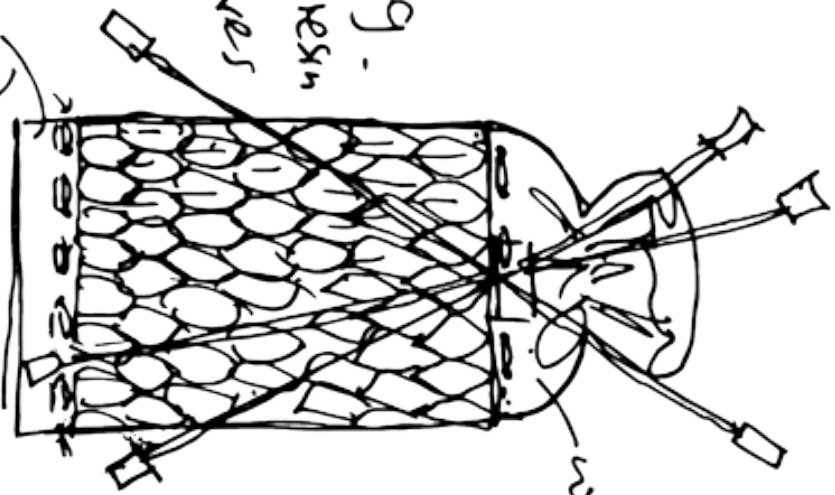

waxed



Process





2nd sample 1 1/2 out



1st out 1 1/2 out



1 box plus



1 specimen



40°



mostly green

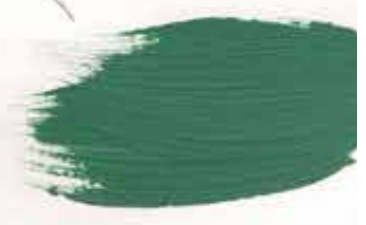

more grey



more grey



solid green

